

219s-09 Triangle Clutch



Suggested yarn:

- Pierrot Yarns Raffia [100% rayon; 124 yds/113m per 1.8 oz./50g skein];
 - version A: color #72 coconut, 3 skeins [135g]
 - version B:
 - color #83 milk white, 2 skeins [70g]
 - color #85 pink orange, 2 skeins [70g]

Tools/Notions:

- 3.5mm (US E) crochet hook or size necessary to achieve gauge
- 1 zipper (20cm/7.9") with circular zipper pull per pouch
- 1 piece of cotton twill tape (25mm/1.0" wide, 10cm/3.9" long) per pouch
- 1 ring-shaped purse handle (10cm/3.9" diameter) per pouch
- 1 piece of leather cord for zipper pull (9mm/0.4" wide, 70mm/2.8" long) per pouch

Finished measurements:

- Please refer to schematics.

Gauge (10cm/4" square):

- pattern stitch: 14 sts and 14 rows

Gauge may vary according to individual crochet style. Change hook size if necessary to achieve gauge. Alternatively, rework pattern with your own gauge measurements.

Summary

✳️**Note 1:** Like all Japanese patterns, stitch counts given here for foundation chains do not include any chain sts needed for turning posts.

✳️**Note 2:** Entire pouch worked with 2 strands of yarn held together (except for whipstitch seam, which should be done with just 1 strand).

Body of pouch: Work foundation chain to begin, then work in sc.

Finishing: Sew zipper to foundation edge and bind-off edge as shown in finishing schematic. Seam section ● to ● and ○ to ○, respectively, using whipstitch (1 strand of yarn). Attach handle to pouch as indicated in finishing schematic, then seam ☆ to ☆ with whipstitch. Fasten leather cord to zipper pull tab to use as zipper pull.

Abbreviations:

ch = chain RS = right side sc = single crochet (US)

Body of pouch

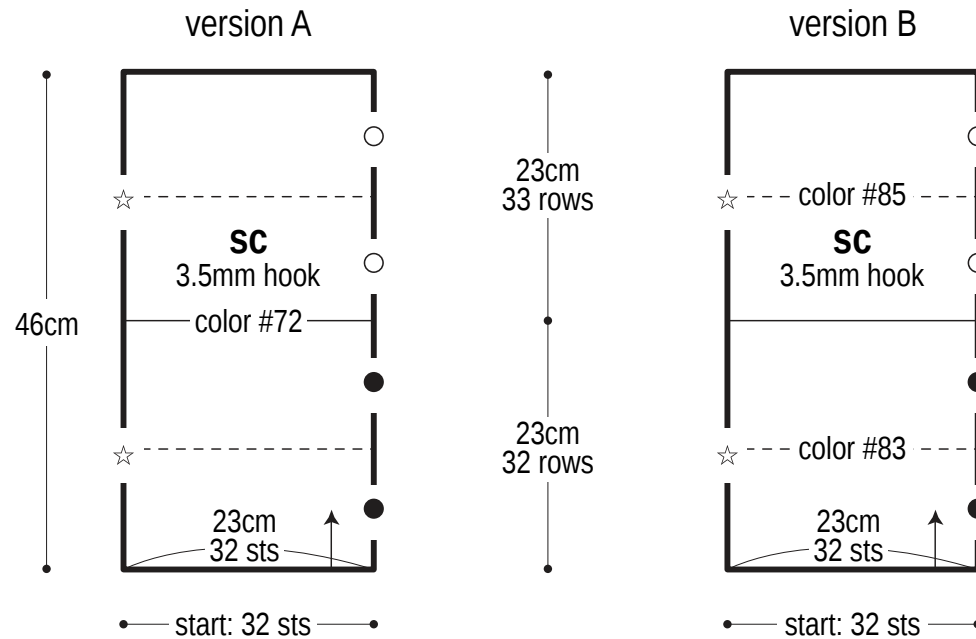

Finishing

※For version A, work whipstitch seam with yarn that matches the piece you're seaming. For version B, use any color you wish.

① With sewing thread, sew one side of zipper to foundation edge and the other to the bind-off edge. Whipstitch with Raffia yarn where indicated.

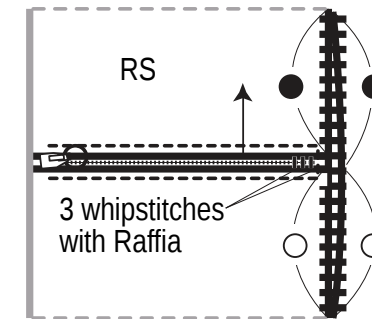

② With wrong sides facing each other, seam ● to ● and ○ to ○.

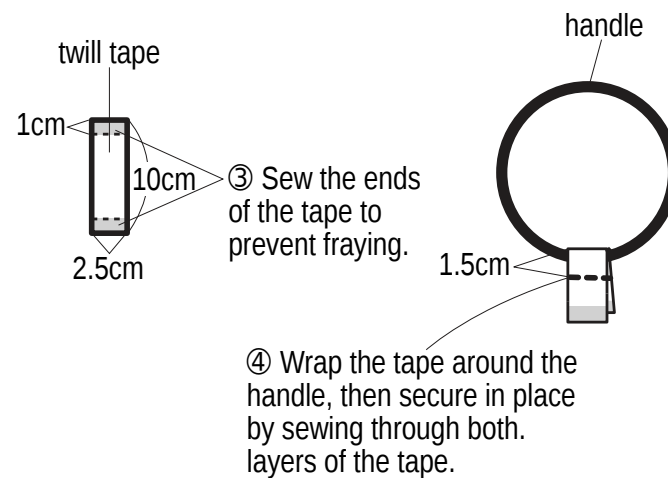
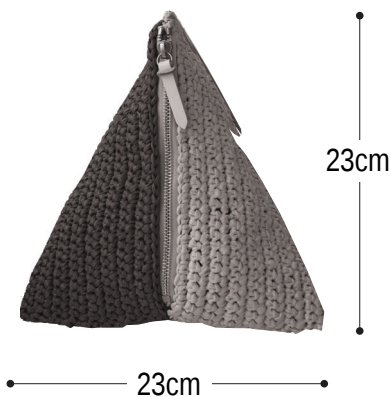

⑤ Using Raffia in the same color as the body of the pouch, insert twill tape between layers marked with ☆ as shown.

⑥ Seam sections marked with ☆ with whipstitch.

⑦ Attach zipper pull to zipper's pull tab.

