

216ss-16 Marshmallow Rompers



Suggested yarn:

- Pierrot Yarns Marshmallow Cotton [100% cotton; 153 yds/140m per 1.06 oz./30g skein];
 - color #12 baby mint, 5 skeins [135g]

Tools/Notions:

- 2.3mm (approx. US B) crochet hook or size necessary to achieve gauge
- 3.3mm (approx. US 3) knitting needles or size necessary to achieve gauge
- 2 buttons (13mm/0.51")

Finished measurements:

- chest 60cm/23.62"
- back length (excluding shoulder straps) 38.5cm/15.16"

Gauge (10cm/4" square):

- pattern stitch: 25 sts and 20 rows
- double crochet (US): 25 sts and 14.5 rows

Gauge may vary according to individual crochet style. Change hook size if necessary to achieve gauge. Alternatively, rework pattern with your own gauge measurements.

Summary

✳️**Note:** Like all Japanese patterns, stitch counts given here for foundation chains do not include any chain sts needed for turning posts.

Back & front: Work foundation chain to begin, then work pattern stitch in joined rounds. Work crotch section back and forth in rows. Knit k1p1 ribbing, then bind off in pattern. Pick up stitches from foundation chain at leg cuff area; work k1p1 ribbing in the round. Bind off in pattern. With crochet hook, work 1 row of sc along bind-off edge of ribbing at chest area for front and back, then continue in dc.

Finishing: Crochet 2 shoulder straps and seam to body. Seam crotch with whipstitch and mattress stitch (see finishing schematic). Sew buttons to front bib.

Abbreviations:

ch = chain
dc = double crochet (US)
k = knit
p = purl
PU = pick up
rep = pattern repeat(s)
sc = single crochet (US)

Back

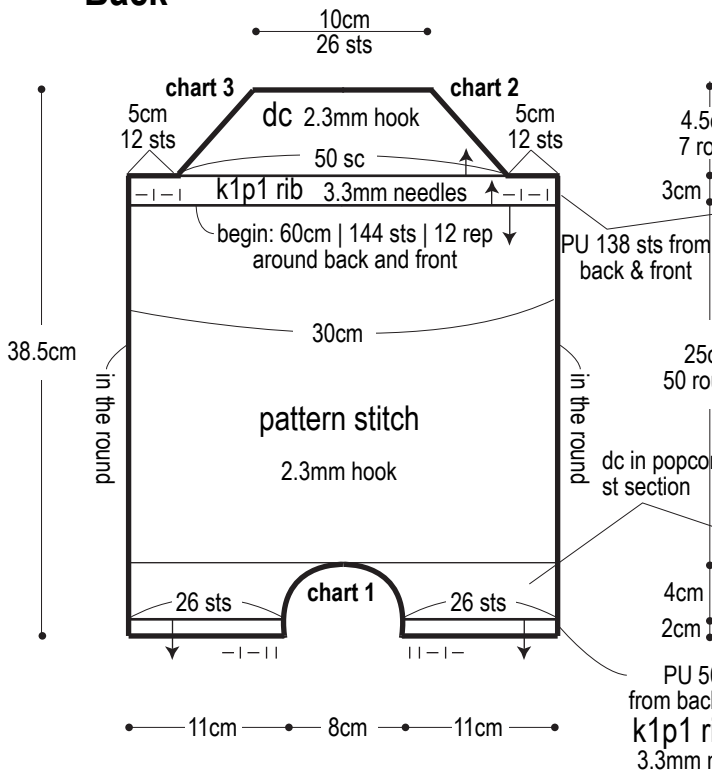

Front

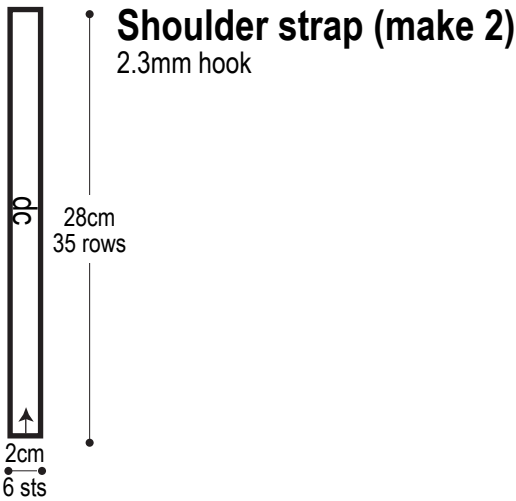
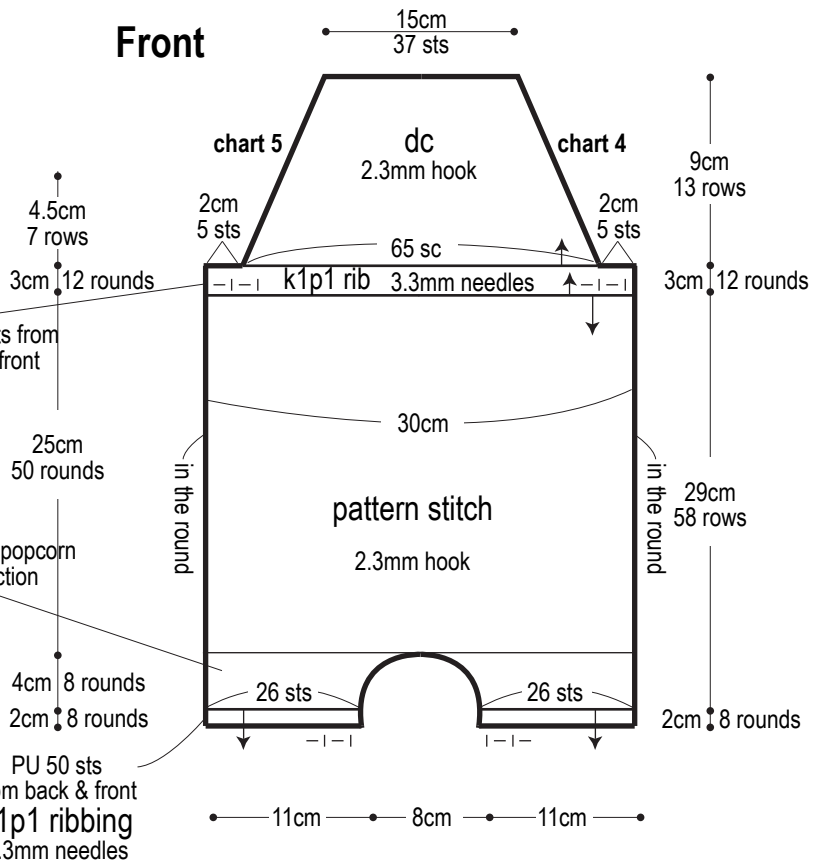

Pattern stitch 2.3mm hook

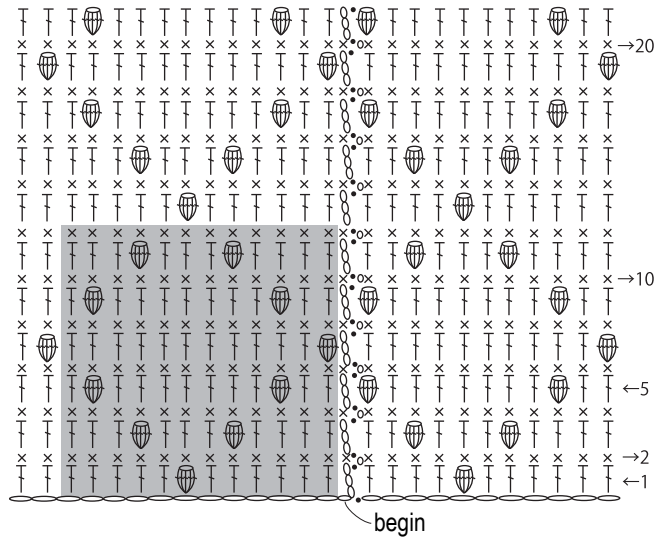

5-dc popcorn stitch

1 repeat
12 sts & 12 rows

Use QR code on smartphone to view a video tutorial about how to work the 5-dc popcorn stitch.



※To view on computer, search on the Pierrot Yarns website or YouTube channel instead.

検索

Back bib 2.3mm hook

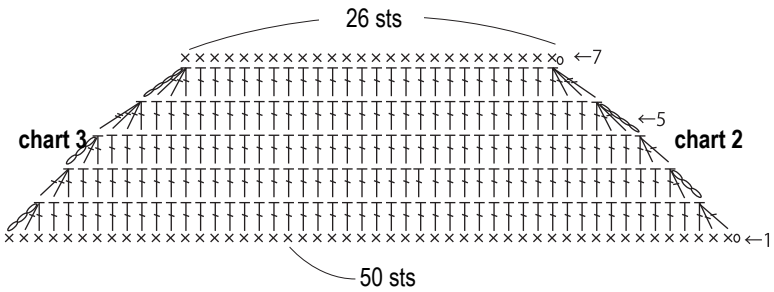

Front bib 2.3mm hook

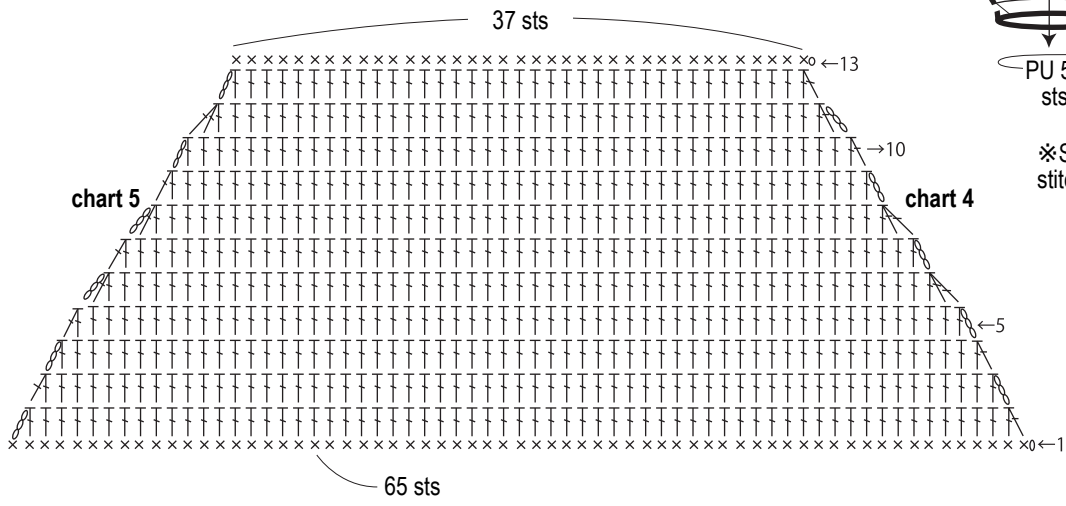

Crotch section 2.3mm hook

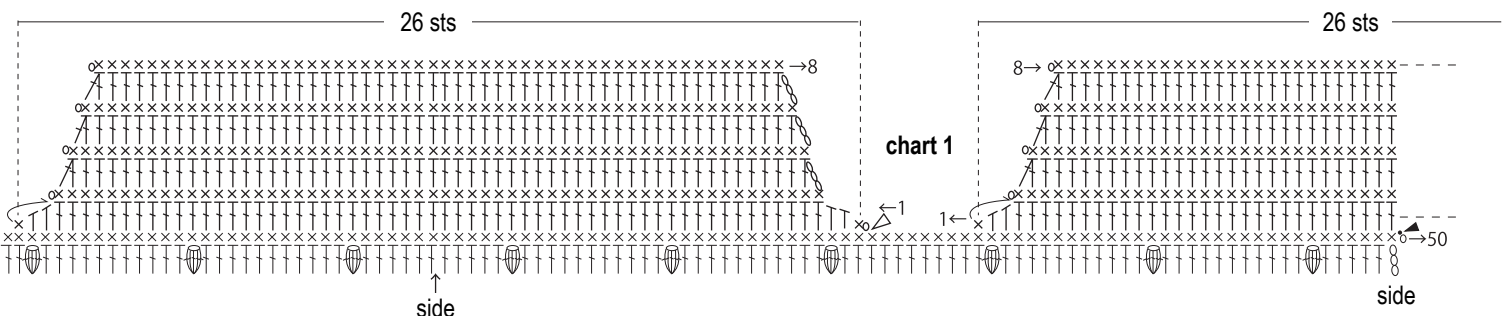

- ◁ = join yarn
- ◄ = cut yarn
- ⤵ = carry yarn

Finishing

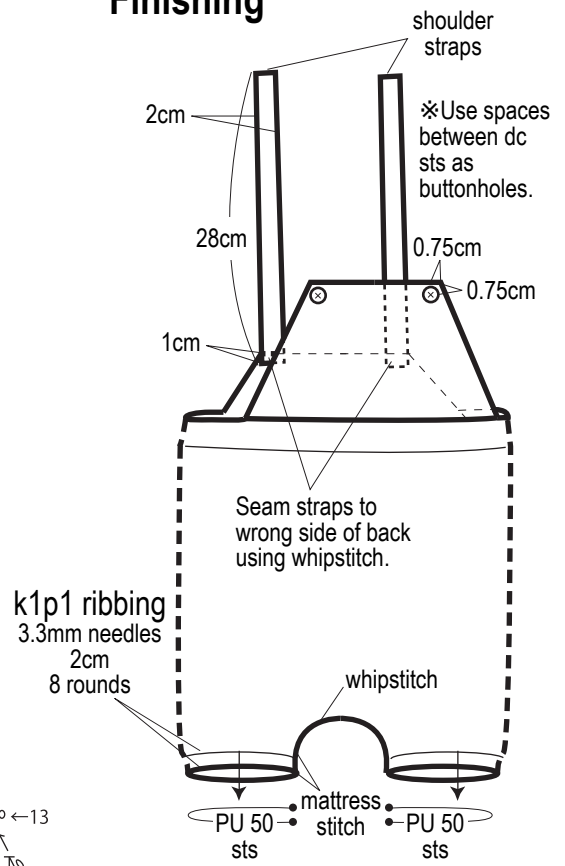

*Seam crotch area with mattress stitch and whipstitch as shown.