

215ss-14 Poppy Shade



Suggested yarn:

- Pierrot Yarns Heat+ [100% polyester; 113 yds./103m per 1.41 oz./40g cone]; color #04 lemon yellow, 3 cones [110g]

Tools/Notions:

- 2.5mm (approx. US B or C) crochet hook or size necessary to achieve gauge

Finished measurements:

- diameter 30.5cm/12.01"
- height 21.5cm/8.46"

Gauge may vary according to individual crochet style. Change hook size if necessary to achieve gauge. Alternatively, rework pattern with your own gauge measurements.

Summary

✿**Note:** Like all Japanese patterns, stitch counts given here for foundation chains do **not** include any chain sts needed for turning posts.

Body of lamp: ch40 and join into the round. Work in pattern stitch, increasing as you work downwards toward bottom edge of lamp.

Finishing: With wrong side out, place shade on a ball or other round object. Lightly block with iron **without** steam. Turn shade right side out, then place back on round object and block with steam to harden yarn. Crochet cord and thread through upper opening. Fasten light socket in place with cord.

Abbreviations:

ch = chain

rep = pattern repeat(s)

sc = single crochet (US)

Poppy shade

2.5mm hook

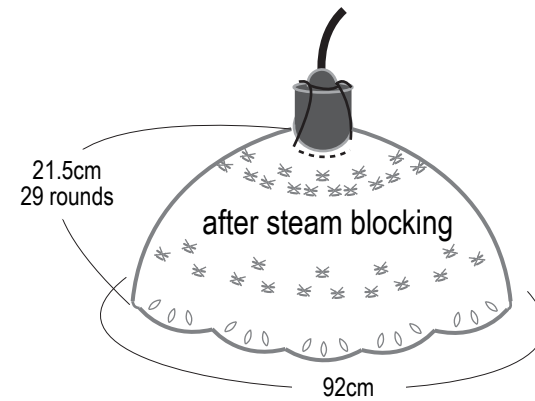
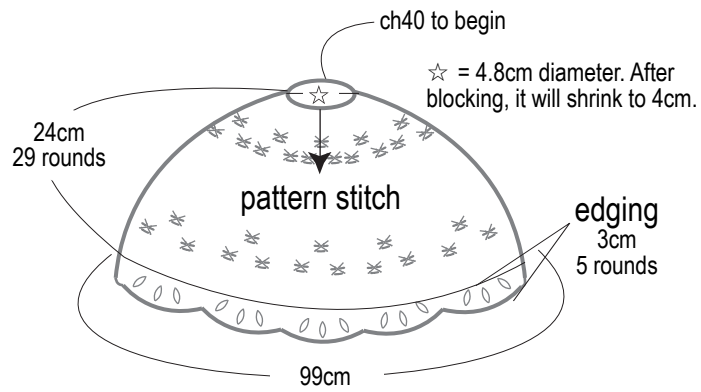

Cord

2.5mm hook

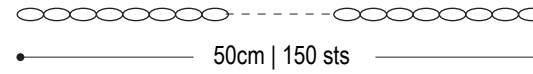

Poppy shade
2.5mm hook

edging
3cm
5 rounds

10-st rep X 22

22-st rep X 10

220 sts

**Increases
in pattern st**

round no.	st count
29	220 sts (work even)
28	220 sts (+10)
27	} 210 sts (work even)
~	
25	} 210 sts (+10)
24	
23	} 200 sts (work even)
~	
20	} 200 sts (+10)
19	
18	} 190 sts (work even)
~	
13	190 sts (+20)
11	170 sts (+20)
10	150 sts (work even)
9	150 sts (+20)
8	130 sts (+20)
7	110 sts (+20)
6	90 sts (+10)
5	80 sts (+10)
4	70 sts (+10)
3	60 sts (+10)
2	50 sts (+10)
1	40 sts (sc)

ch40 to begin

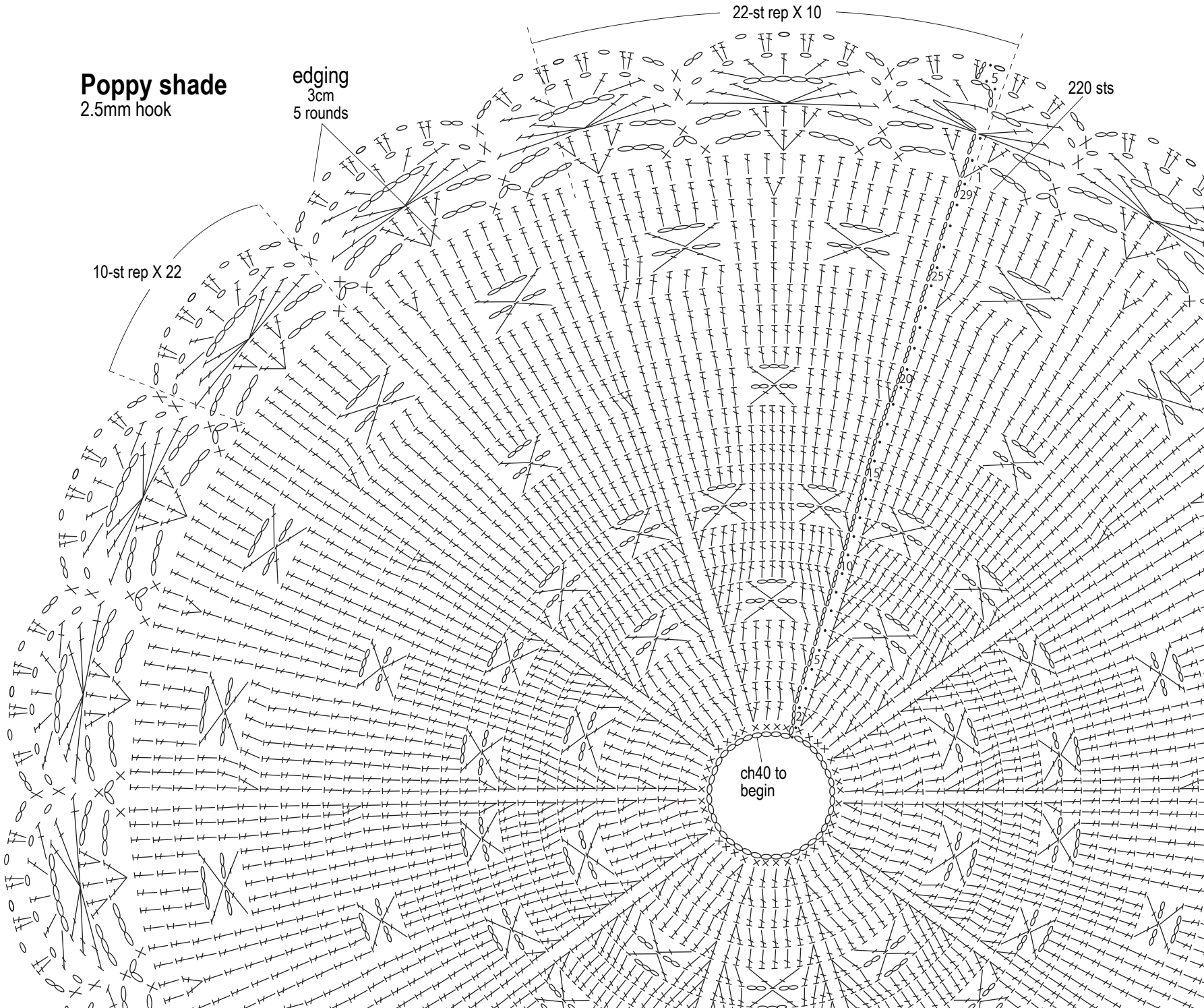

HEAT+ stiffening method (using steam iron)

Lightly iron dry fabric without steam.

Hold iron slightly above fabric; steam thoroughly.

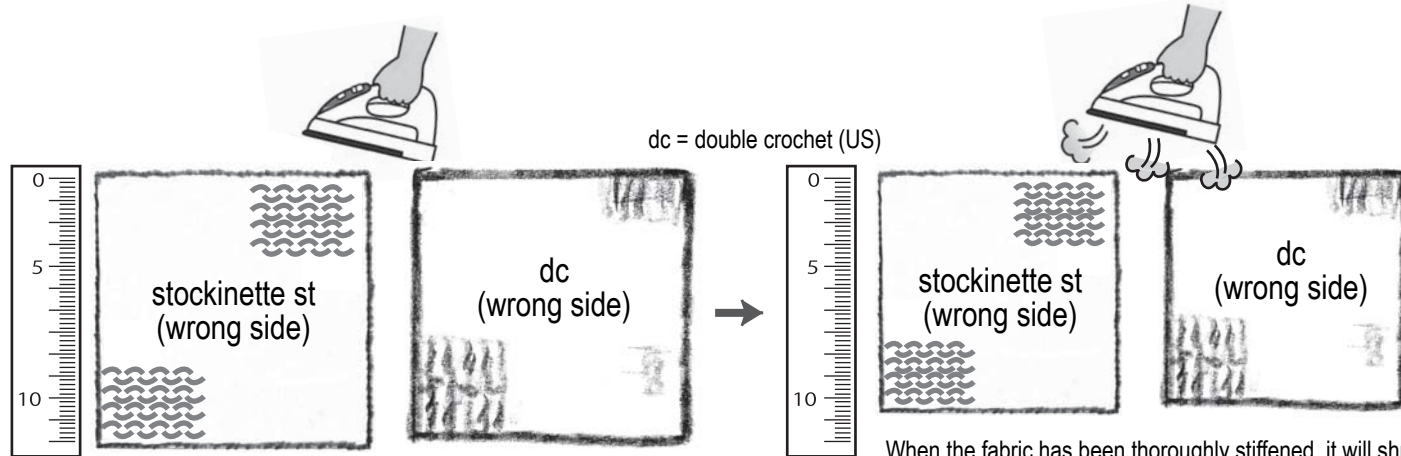

Iron directly on top of flat knitted or crocheted fabric.
If the fabric is not uniform, stretch the fabric into shape.
*Set iron to medium heat.

*Adjust the fabric's degree of hardness by adjusting your steam iron's settings. The temperature setting needed to produce steam may vary from medium to high heat depending on your iron.

When the fabric has been thoroughly stiffened, it will shrink about 10%.
Amount of shrinkage will depend on individual stitches and stitch patterns.

How to iron cubes and round objects

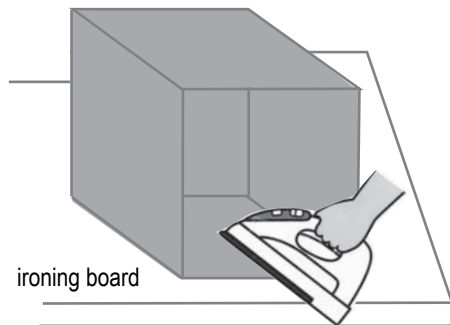

*Block flat items with an iron (without steam) first. Depending on the object, there may be times when you want to steam it first.

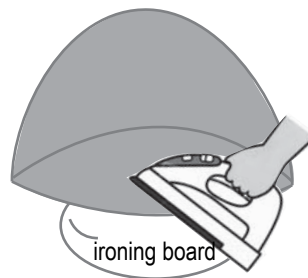

*When ironing, don't use a towel or other fabric that will pill or transfer fluff onto your item. Fuzz may stick to the item as the item shrinks and stiffens.

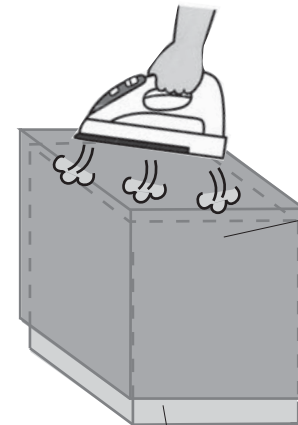

Place item on top of mold, then steam thoroughly with iron.



Use bowl or other round item to steam round objects. (Be sure that the item can withstand steam from iron.)