

213w-23 Pochette 2-way Pants



Suggested yarn:

- Pierrot Yarns Pochette [50% superwash merino wool, 50% cotton; 131 yds/120m per 1.41 oz./40g skein]; color #09 violet, 11 skeins [405g]

Tools/Notions:

- 3.0mm (US 2½) and 5.1mm (approx. US 8) straight and double-pointed knitting needles or sizes necessary to achieve gauge
- 2.3mm (approx. US B) crochet hook or size necessary to achieve gauge
- 2 buttons (15mm/0.59")
- elastic for waistband (1cm/0.39" wide, 160cm/62.99" long)

Finished measurements:

- waist circumference 59cm/23.23"
- length 53.5cm/19.29"

Gauge (10cm/4" square):

- stockinette stitch (with 5.1mm needles): 18 sts and 26 rows
- k1p1 ribbing (with 3.0mm needles): 30 sts and 35 rows

Gauge may vary according to individual knitting style. Change needle size if necessary to achieve gauge. Alternatively, rework pattern with your own gauge measurements.

Knitting Tips

❖**Note:** All stockinette stitch sections should be worked with 2 strands of yarn held together. Use just 1 strand of yarn for k1p1 ribbing sections.

Lower section: Cast on with long-tail cast-on method. Work in stockinette stitch. Reverse shaping of lower right section for lower left section. Seam crotch with mattress stitch. Seam crotch rise from front to back in one continuous mattress stitch seam.

Upper section: Pick up stitches from lower section; work stockinette stitch in the round. Bind off. Pick up stitches around waistline and ankle cuffs, respectively; work k1p1 ribbing in the round with 1 strand of yarn. Bind off in pattern.

Finishing: At waist and cuffs, fold ribbing at fold line to inside of garment. Leaving a gap unseamed for threading the elastic through, tack down ribbing with whipstitch. Thread elastic through waistband and cuffs. Sew upper section where indicated; thread 2 pieces of elastic through waistband. Work shoulder straps in k1p1 ribbing. Crochet two columns of slip stitch along two purl rows as marked. Sew shoulder straps to back of pants. Sew buttons to front of pants.

Abbreviations:

BO = bind off CO = cast on OH = on hold (that is, place stitches on stitch holder) PU = pick up RE = row(s) even ### = rows-stitches-times

Right lower leg

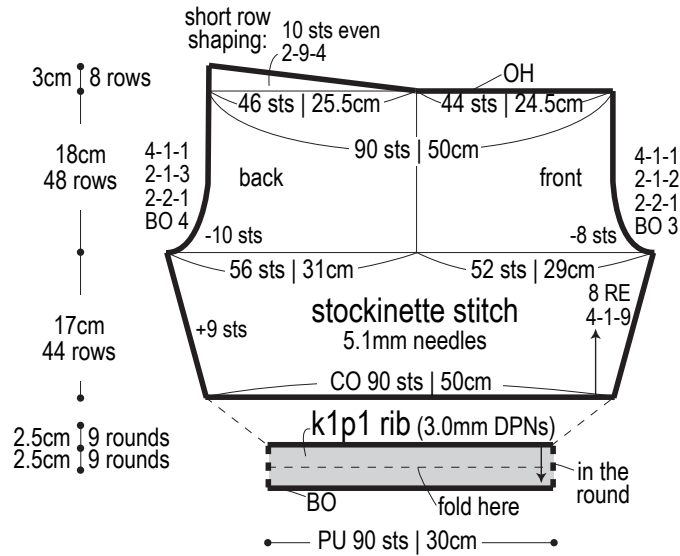

Schematic

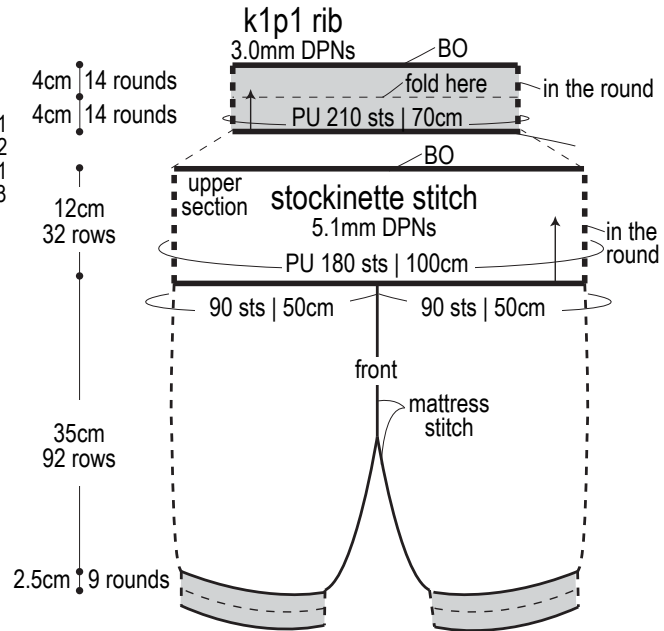

Finishing

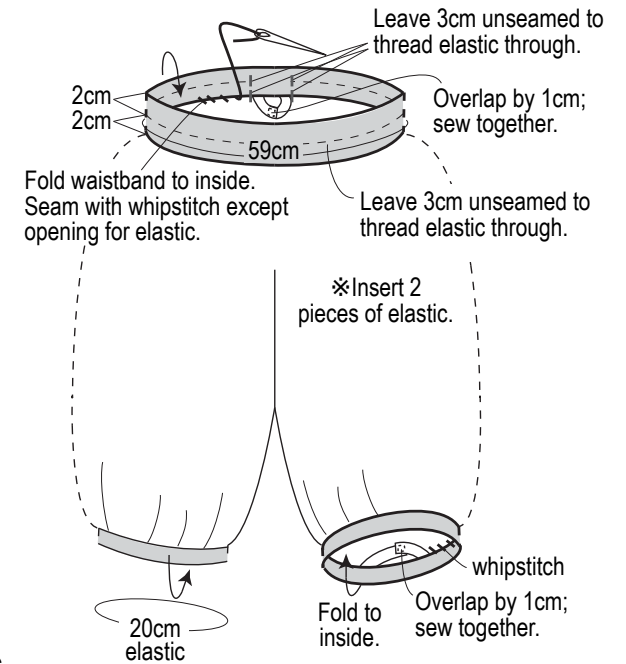

How to seam shoulder straps

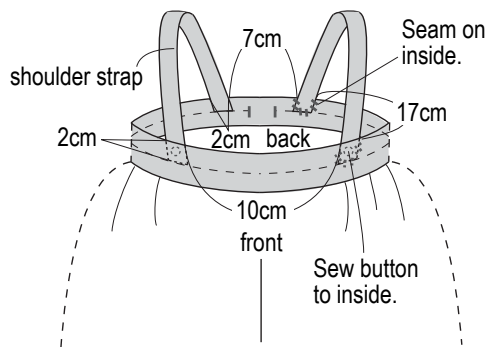

Shoulder straps

make 2

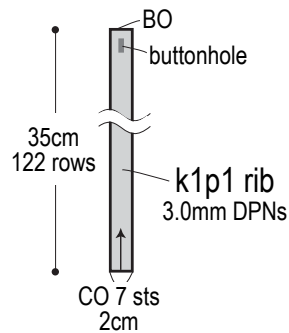

Shoulder straps

3.0mm needles

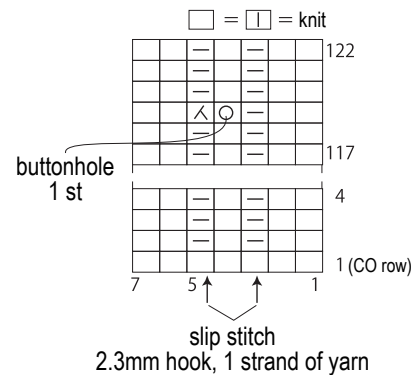

*Adjust length of elastic at waist and ankles as desired.

■ = k1p1 ribbing (1 strand of yarn)