

212w-04 Silk Rosa Long Sweater



Suggested yarn:

- Pierrot Yarns Silk Rosa [75% super kid mohair, 25% silk; 213 yds/195m per 0.88 oz./25g skein];
 - color #03 loam brown, 2 skeins [30g]
 - color #05 antique rose, 5 skeins [115g]
- Pierrot Yarns Junmo Chuboso [50% merino wool, 50% other wool; 164 yds/150m per 1.41 oz./40g skein];
 - color #308 light violet, 6 skeins [225g]
 - color #328 sepia, 2 skeins [50g]
- Pierrot Yarns Kirara [89% acetate, 11% polyester; 1892 yds/1730m per 1.76 oz./50g cone]; color #05 beige silver lamé, 1 cone [40g]

Tools/Notions:

- 4.8mm (approx. US 8) straight knitting needles or size necessary to achieve gauge
- 4.5mm (US 7) and 4.8mm (approx. US 8) double-pointed knitting needles or sizes necessary to achieve gauge

Finished measurements:

- bust 96cm/37.80"
- cross back width 40cm/15.75"
- length 70cm/27.56"
- sleeve length 50cm/19.69"

Gauge (10cm/4" square):

- stockinette stitch: 19 sts and 26 rows

Gauge may vary according to individual knitting style. Change needle size if necessary to achieve gauge. Alternatively, rework pattern with your own gauge measurements.

Knitting Tips

※Note: Entire garment is worked with 3 strands of yarn held together (1 strand of Silk Rosa, 1 strand of Junmo Chuboso, and 1 strand of Kirara).

Hem & cuffs: Cast on with long-tail cast-on method. Work 18 rows in stockinette stitch, then place all stitches on stitch holder. (Refer to chart for colors.)

Back & front body: Cast on with long-tail cast-on method. Work 13 rows in stockinette stitch. Knit one row of body and hem together, effectively seaming them. Continue working in stockinette stitch, decreasing at edges as indicated. For front only, work mouth of pocket on row 31 by knitting required number of stitches on waste yarn in a contrasting color.

Sleeves: Cast on with long-tail cast-on method. Work 13 rows in stockinette stitch. Knit one row of body and cuff together, effectively seaming them. Continue working in stockinette stitch, increasing at edges as indicated.

Finishing: Knit pocket according to chart. Seam shoulders with crochet slip stitch. Seam sleeves and underarm together where marked with ★ and ☆ using stitches-to-rows mattress stitch. Seam sides and sleeve undersides in one continuous mattress stitch seam. Work outer collar in stockinette stitch in the round. Then change color and work inner collar with 4.5mm needles in stockinette stitch in the round.

Abbreviations:

BO = bind off CO = cast on OH = on hold (place sts on stitch holder) PU = pick up RE = row(s) even ### = rows-stitches-times

Back

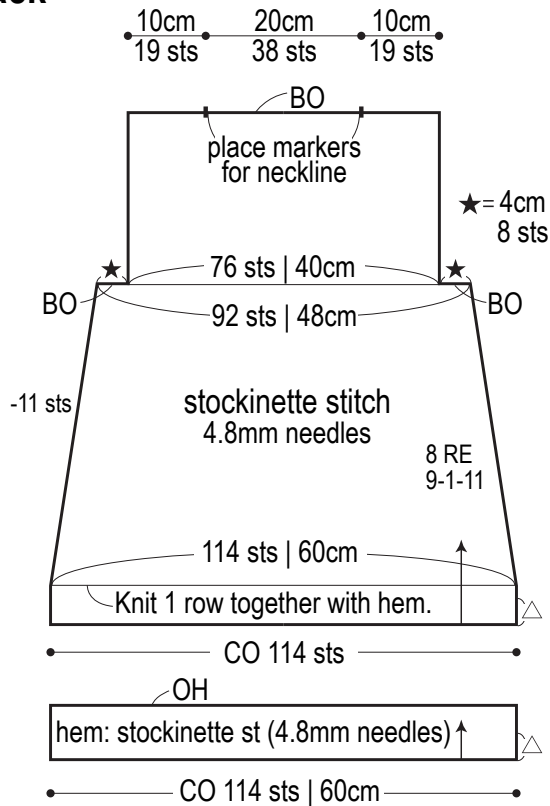

Front

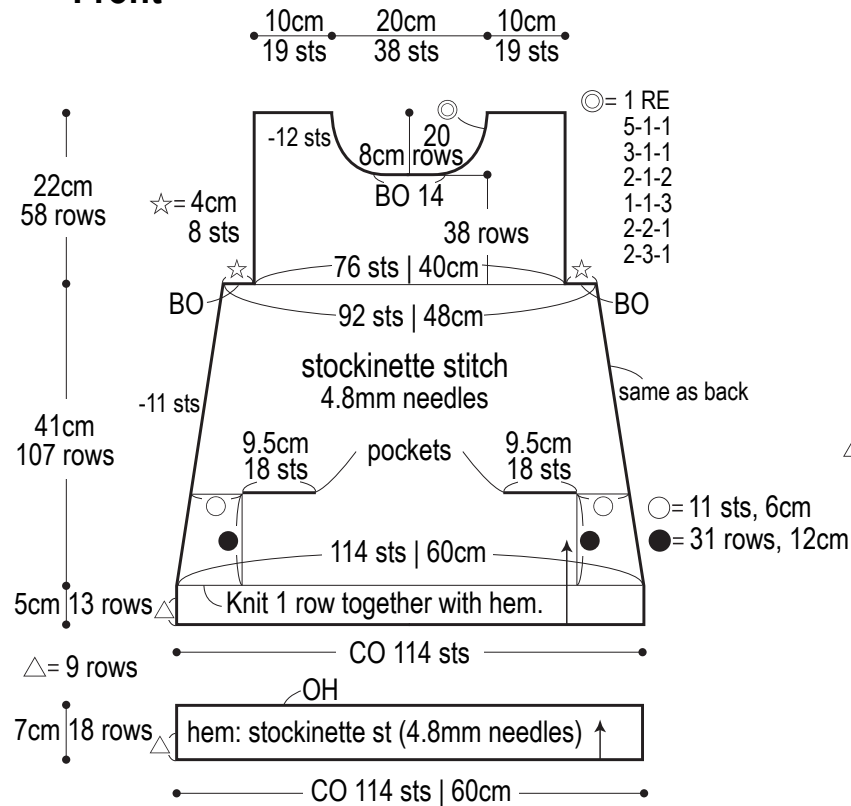

Sleeve

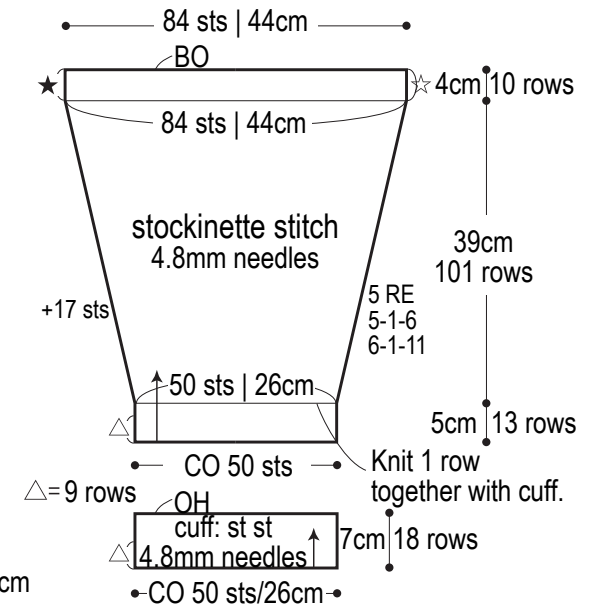

※For the areas marked with \triangle , work mattress stitch seam on wrong side so that seam will not show when the hem curls up.

※Color sequences

Body & sleeves: work with 3 strands held together (1 strand Silk Rosa color #05 antique rose, 1 strand Junmo Chuboso color #308 light violet, and 1 strand Kirara color #05 beige silver lamé)

Hem, cuff, inner collar, & pockets: work with 3 strands held together (1 strand Silk Rosa color #03 loam brown, 1 strand Junmo Chuboso color #328 sepia, and 1 strand Kirara color #05 beige silver lamé)

Pocket

4.8mm needles

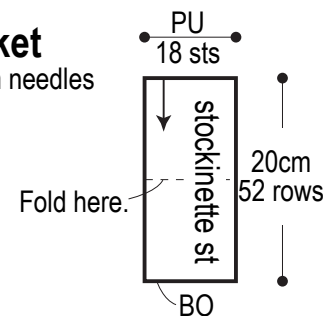

Use this QR code on your smartphone to view a video about how to work the stitches-to-rows seam.



※To view on computer, search on the Pierrot Yarns website instead.

検索

Outer collar

Silk Rosa, color #05 antique rose
 Junmo Chuboso, color #308 light violet
 Kirara, color #05 beige silver lamé

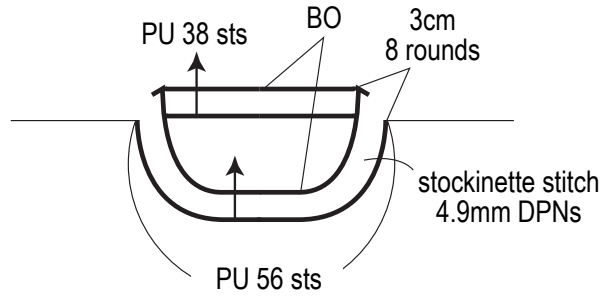

Inner collar

Silk Rosa, color #03 loam brown
 Junmo Chuboso, color #328 sepia
 Kirara, color #05 beige silver lamé

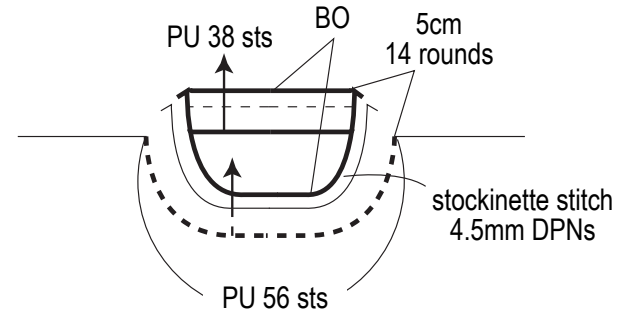

Pockets

Silk Rosa, color #03 loam brown
 Junmo Chuboso, color #328 sepia
 Kirara, color #05 beige silver lamé

