

211w-14 Aspen Pullover



Suggested yarn:

- Filatura Botto Poala Aspen 3 [100% cashmere; 107 yds/98m per 0.88 oz./25g skein]; color #05 coconut, 10 skeins [245g]

Tools/Notions:

- 3.3mm (approx. US 3) and 3.9mm (approx. US 6) straight knitting needles or sizes necessary to achieve gauge
- 3.3mm (approx. US 3) double-pointed knitting needles or size necessary to achieve gauge

Finished measurements:

- bust 92cm/36.22"
- cross back width 34cm/13.39"
- back length 62.5cm/24.61"
- sleeve length 55cm/21.65"

Gauge (10cm/4" square):

- stockinette stitch: 23 sts and 29 rows

Gauge may vary according to individual knitting style. Change needle size if necessary to achieve gauge. Alternatively, rework pattern with your own gauge measurements.

Knitting Tips

Back & front body: Cast on with crochet provisional cast-on method. Work in stockinette stitch.

Side: Cast on as for body. Work hem, increasing as shown in chart. Decrease at both side edges, then work up until shaping for the armscye begins

Sleeve: Cast on as for body. Working decreases and increases as indicated, knit lower sleeve. Shape sleeve cap by binding off stitches as indicated and by working fully fashioned decreases (1 stitch in from the edge) at each edge.

Finishing: Remove provisional cast-on edge at hem and cuffs; pick up live stitches and work in k1p1 ribbing. Bind off with 1x1 tubular bind-off method. Seam shoulders with crochet slip stitch. Seam sides and sleeve undersides with mattress stitch. Seam sleeves to body with crochet slip stitch. Pick up stitches around neckline; work collar in k1p1 ribbing in the round. Bind off with 1x1 tubular bind-off method.

Abbreviations:

BO = bind off
CO = cast on
PU = pick up
RE = row(s) even
= rows-stitches-times

Back

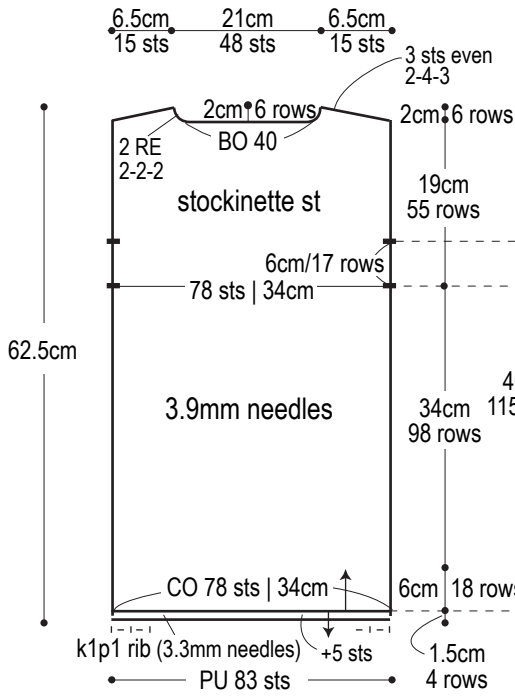

Front

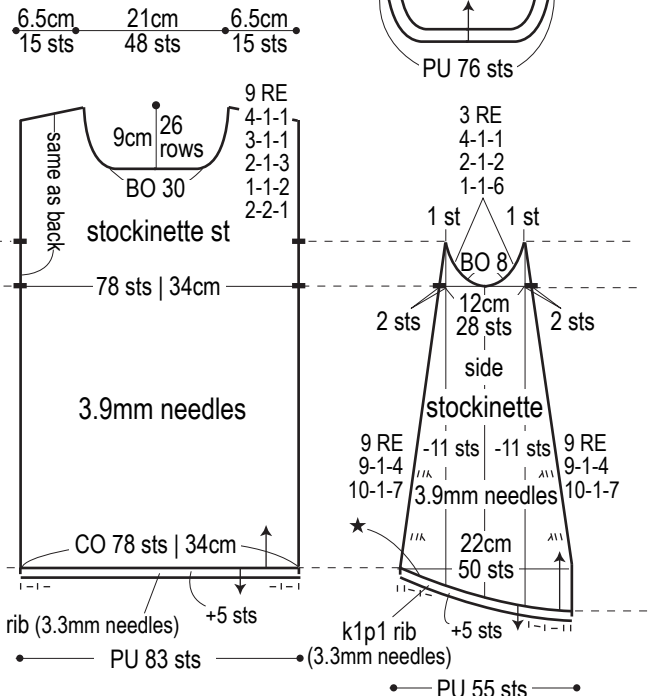

Collar

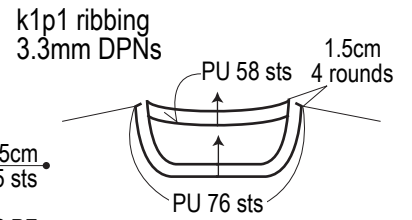

Side hem increases

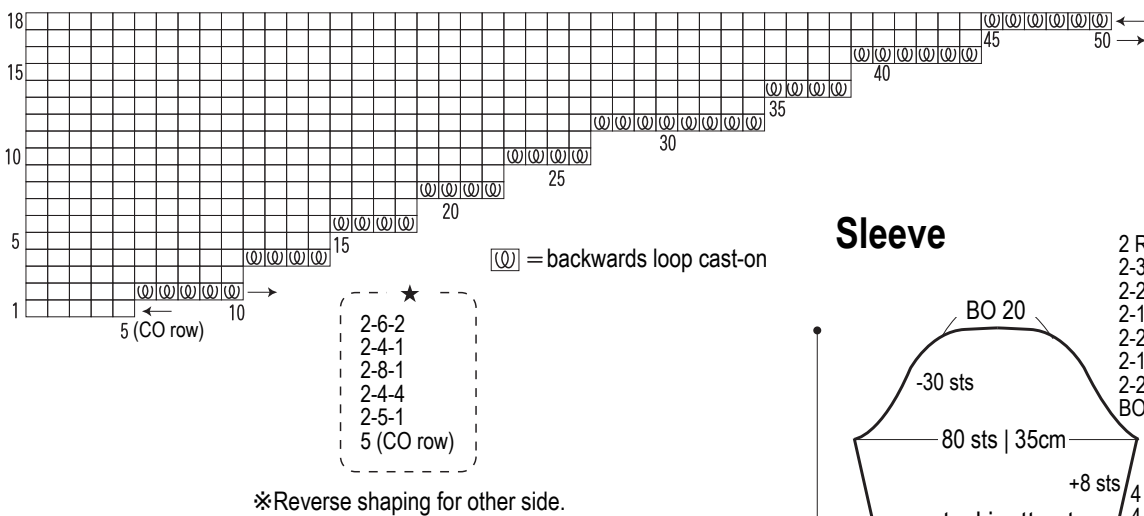

Sleeve

