

212ss-20 Drop-stitch French Pullover



Suggested yarn:

- Pierrot Yarns Celeste [45% cotton, 40% wool, 15% nylon; 208 yds/190m per 1.76 oz./50g skein]; color #02 gray/blue/magenta, 6 skeins [260g]

Tools/Notions:

- 2.7mm (approx. US 2) and 3.3mm (approx. US 3) straight knitting needles or sizes necessary to achieve gauge
- 2.7mm (approx. US 2) double-pointed knitting needles or size necessary to achieve gauge

Finished measurements:

- bust 104cm/40.94"
- center back neck-to-cuff 29.5cm/11.6"
- length 52.5cm/20.67"

Gauge (10cm/4" square):

- stockinette stitch: 23.5 sts and 36.5 rows
- pattern stitch: 23.5 sts and 22 rows
- k2p2 ribbing: 30.5 sts and 40 rows

Gauge may vary according to individual knitting style. Change needle size if necessary to achieve gauge. Alternatively, rework pattern with your own gauge measurements.

Knitting Tips

Back: Cast on with crochet provisional cast-on method. Work in stockinette stitch. Increase 5 stitches (using backwards loop cast-on method) at each underarm. Pick up live stitches at hem; work edging in k2p2 ribbing. Bind off in pattern.

Front: Cast on as for back; work in pattern stitch. Work up until underarm, then increase 5 stitches on each side. Continue in pattern stitch, up until start of neckline shaping. Work remaining 16 rows in stockinette stitch. Work hem in same manner as for back.

Finishing: Seam shoulders with slip stitch. Seam sides with mattress stitch, but for the underarm increases, seam with woven seam. Work k2p2 ribbing in the round around neckline and sleeves. Bind off in pattern.

Abbreviations:

BO = bind off	RE = row(s) even
CO = cast on	sl st = slip stitch
inc = increase	YO = yarn over
PU = pick up	## = rows-stitches-times

Back

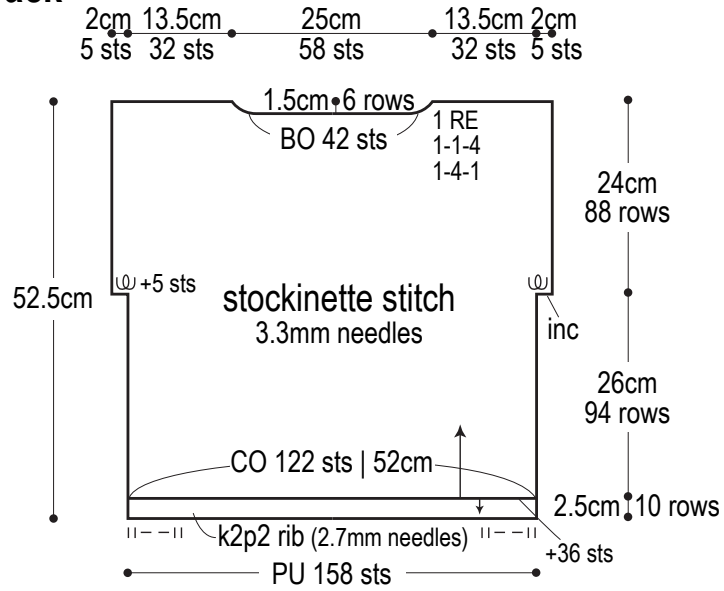

※Use backwards loop cast-on method for increases at underarm.

Front

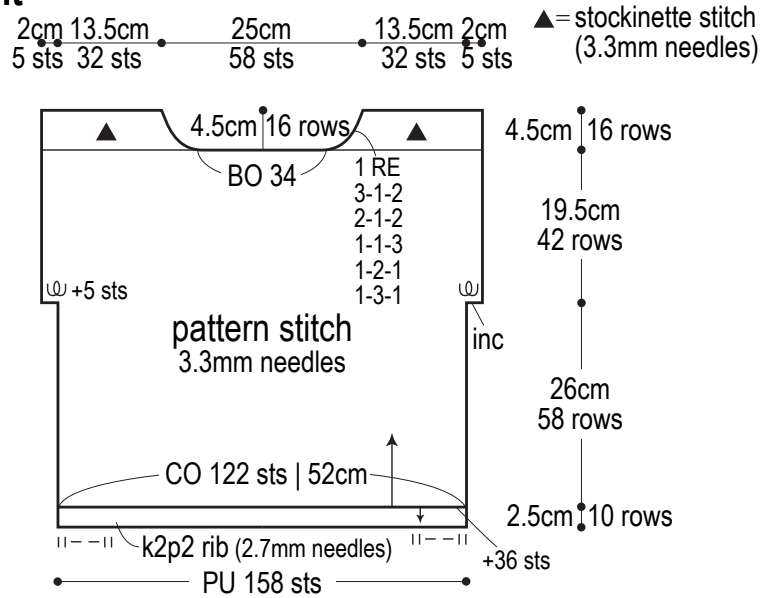

Finishing (2.7mm DPNs)

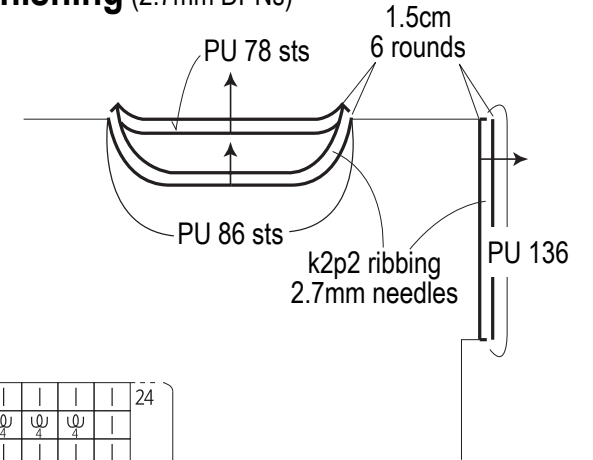

Pattern stitch (3.3mm needles)

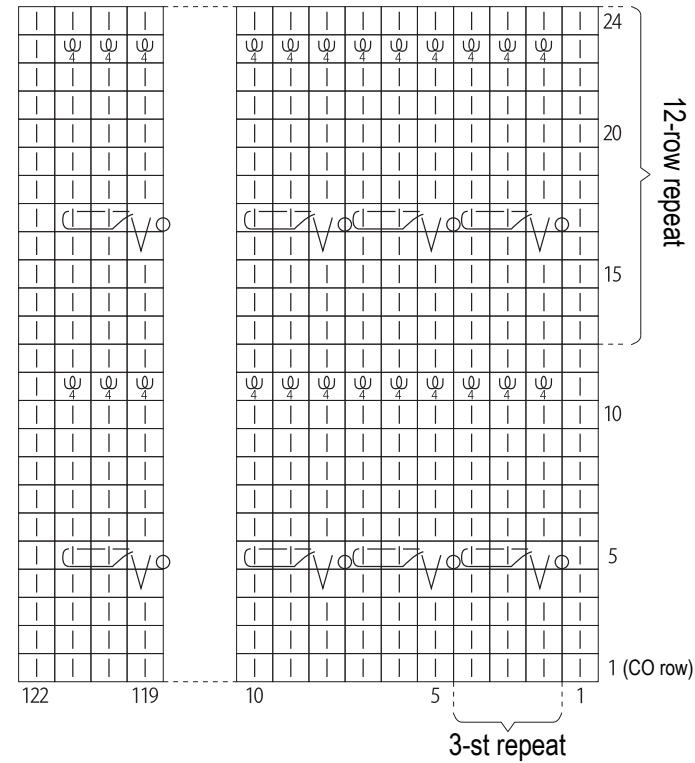

= YO/sl st

= 4-wrap drop stitch

} See next page for instructions.



YO/slip stitch instructions

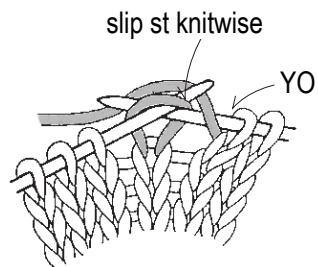

YO, then slip next stitch knitwise onto right needle.

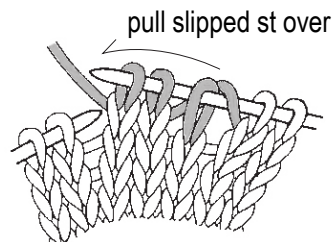

Knit next 2 stitches normally. Pull slipped stitch over these 2 stitches.

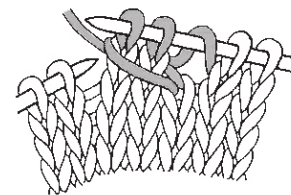

Finished YO/slip stitch.



4-wrap drop stitch instructions

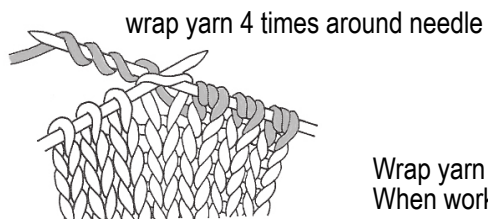

Wrap yarn around right needle four times; knit first stitch on left needle. When working the next row, drop the 4 wrapped stitches off of the needle.