

212ss-03 2-way Dolman Sweater



Suggested yarn:

- Pierrot Yarns Soft Silk Ramie [70% ramie, 30% silk; 514 yds/470m per 3.53 oz./100g cone]; color #23 ginger, 4 cones [320g]

Tools/Notions:

- 5.1mm (approx. US 8) straight knitting needles or size necessary to achieve gauge
- 4.5mm (US 7) double-pointed knitting needles or size necessary to achieve gauge
- 4.0mm (US 6) knitting needles or size necessary to achieve gauge

Finished measurements:

- bust: one size fits most
- center back neck-to-cuff 58cm/22.83"
- length 60cm/23.62"

Gauge (10cm/4" square):

- pattern stitch: 18 sts and 22 rows

Gauge may vary according to individual knitting style. Change needle size if necessary to achieve gauge. Alternatively, rework pattern with your own gauge measurements.

Knitting Tips

※Entire garment worked with 2 strands of yarn held together.

Front & back body; sleeves: Cast on with crochet provisional cast-on method. Work in pattern stitch, increasing with backwards loop cast-on method at sides, sleeve undersides, and cuffs. Decrease at neckline as shown. Shape shoulders with short rows.

Finishing: Seam shoulders with three-needle bind-off. Seam sides with mattress stitch. Seam sleeve undersides with woven seam. Remove provisional cast-on edge from hem; pick up stitches and work k1p1 ribbing. Bind off with 1x1 tubular bind-off method. Pick up stitches around cuff and work k1p1 ribbing in the round. Bind off with 1x1 tubular bind-off method. Crochet slip stitch loosely around neckline.

Abbreviations:

BO = bind off

CO = cast on

PU = pick up

RE = row(s) even

= rows-stitches-times

Back body

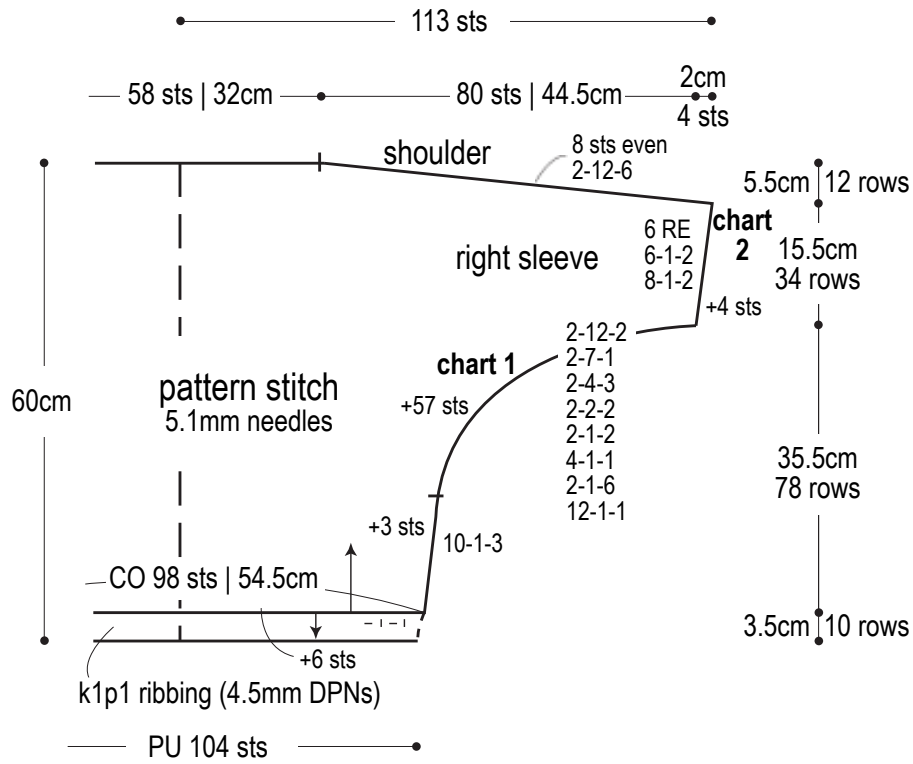

Front body

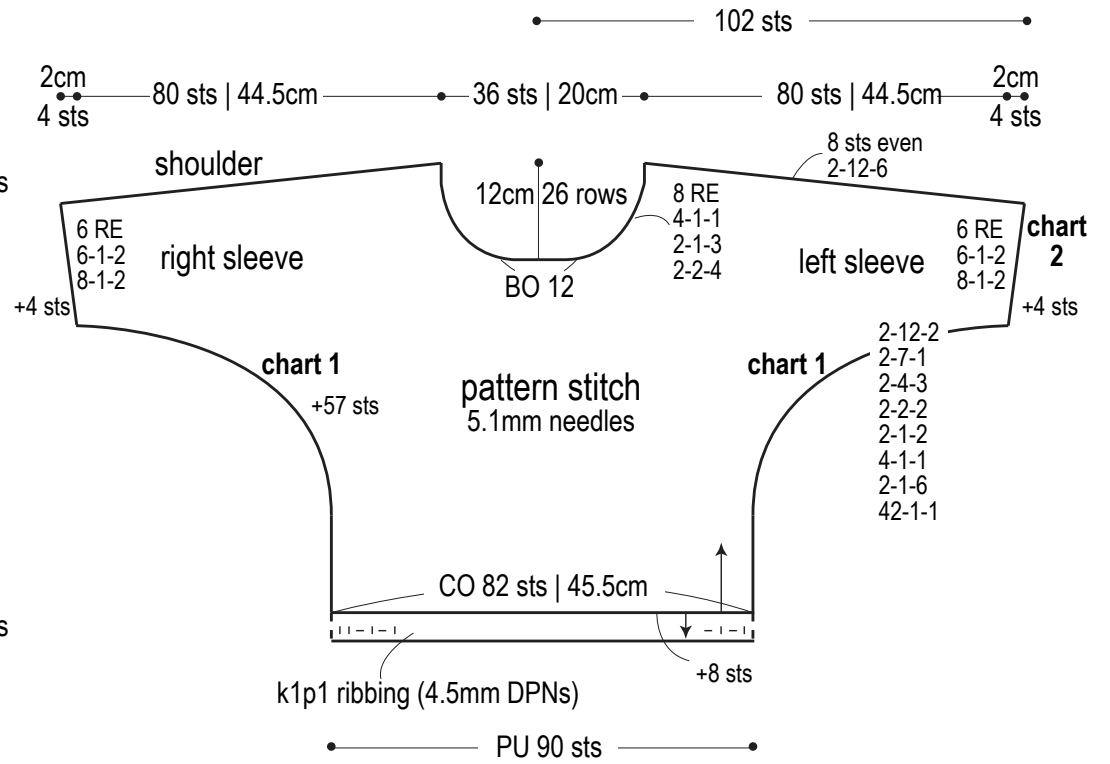

Side & sleeve shaping

