

212ss-05 Beauty Silk Cotton Motif Sweater



Suggested yarn:

- Pierrot Yarns Beauty Silk Cotton [90% cotton, 10% silk; 180 yds/165m per 1.06 oz./30g skein]; color #03 light beige, 10 skeins [295g]

Tools/Notions:

- 3.3mm (approx. US 3) double-pointed knitting needles or size necessary to achieve gauge
- 2.0mm (US steel hook 4) crochet hook or size necessary to achieve gauge

Finished measurements:

- bust 95cm/37.40"
- length 64cm/25.20"

Gauge:

- k1p1 ribbing: 38 sts and 45 rows = 10cm/4" square
- each motif should measure 8cm/3.15" long and 9.5cm/3.74" across (at base)

Gauge may vary according to individual crochet style. Change hook size if necessary to achieve gauge. Alternatively, rework pattern with your own gauge measurements.

Crochet Tips

Front & back body: Crochet the first motif. Starting from the second motif, seam each motif to the points of neighboring motifs, working into the chain stitches in the fourth round of the point. After motifs are finished, pick up 340 stitches around hem (1 st from each motif edge stitch plus 1 stitch at each corner). Work k1p1 ribbing in the round. Bind off with tubular bind-off method.

Finishing: Seam sides with slip stitch, forming into shape of pullover. Be sure not to seam motifs at arm opening.

Abbreviations:

m = magic ring
rep = repeat(s)

Back

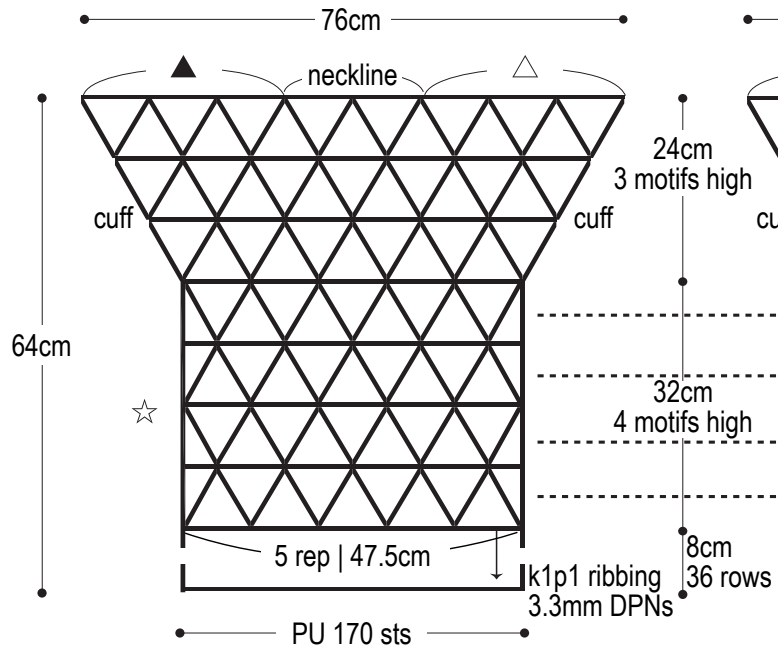

Front

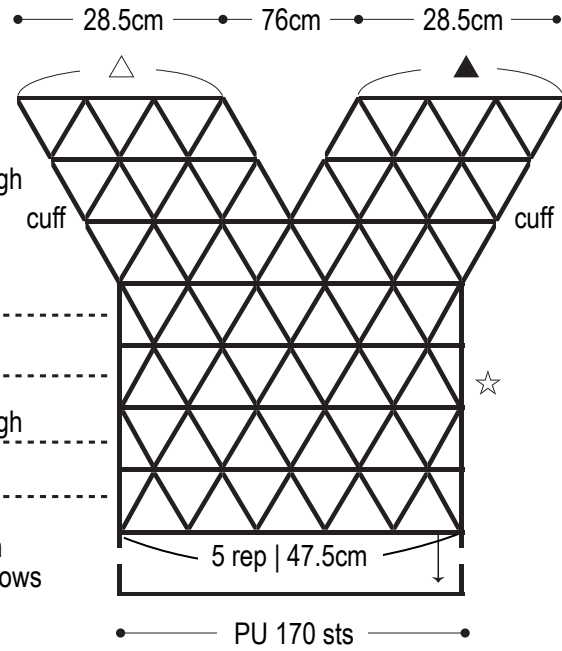

Seam ▲ • △ • ☆ where shown.
Do not seam motifs at arm openings.

Motif (2.0mm hook)

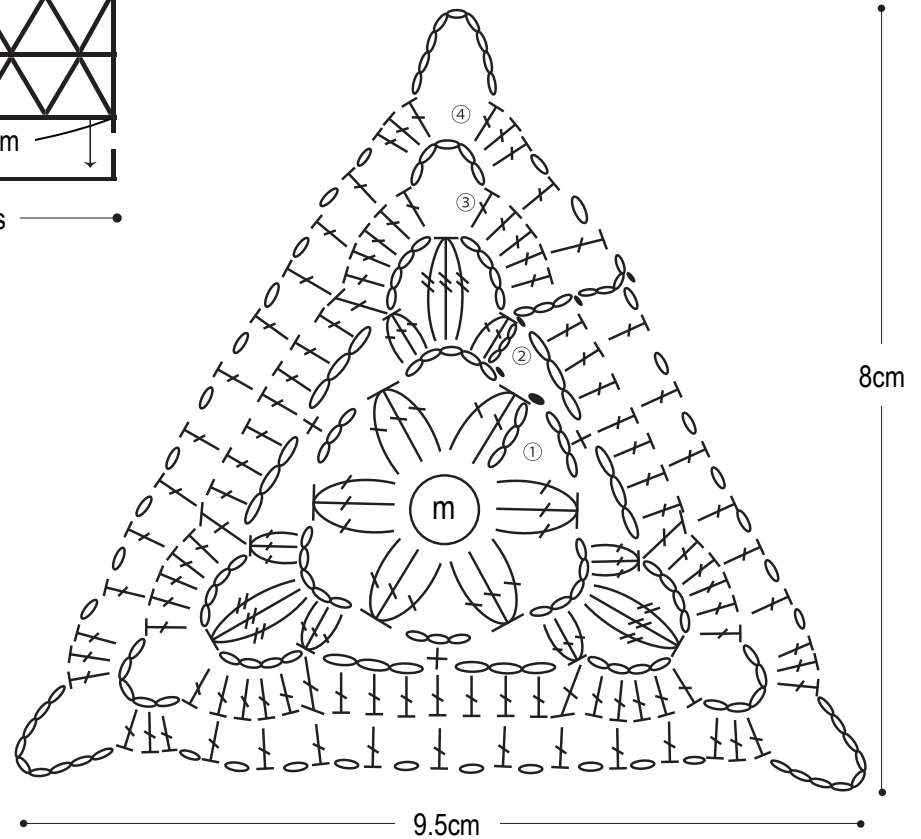

Edging (collar, cuffs)

2.0mm hook



Motif seaming order

On the last round of each motif, seam into chain stitches at the points of the other motifs using slip stitch.

