

# 25-22 V-neck Pullover



## Suggested yarn:

- Pierrot Yarns Tsumugi2 [100% silk; 826 yds/755m per 3.53 oz./100g cone]; color #58 mandarin orange, 3 cones [300g]

## Tools/Notions:

- 3.0mm (US 2½) and 3.6mm (approx. US 4 or 5) straight knitting needles or sizes necessary to achieve gauge
- 2.7mm (approx. US 2) circular knitting needle or size necessary to achieve gauge

## Finished measurements:

- bust 98cm/38.58"
- cross back width 41cm/16.14"
- length 62cm/24.41"
- sleeve length 38cm/14.96"

## Gauge (10cm/4" square):

- pattern stitch: 30 sts and 30 rows

*Gauge may vary according to individual knitting style. Change needle size if necessary to achieve gauge. Alternatively, rework pattern with your own gauge measurements.*

## Knitting Tips

※Entire garment worked with 2 strands of yarn held together.

**Body:** Cast on with crochet provisional cast-on edge and begin knitting. Work in pattern stitch (on the left side of body, slip 2 stitches onto cable needle, hold cable needle at back, k3; on the right side, slip 2 stitches onto cable needle, hold cable needle at front, k3). Always be sure to keep pattern stitch centered, so that right and left sides form a mirror image. For armscye and back neckline, bind off stitches as indicated. For front neckline, work fully fashioned decreases 2 stitches in from the edge, referring to schematics. Pick up lives stitches from provisional cast-on edge at hem. Work evenly spaced decreases in first row, then work in k2p2 ribbing. Bind off with 2x2 tubular bind-off method.

**Sleeves:** Begin as for body. Increase sleeves at seam edge using fully fashioned lifted increases (i.e., worked one stitch in from the edge). Using waste yarn, place markers where sleeve will be seamed to body.

**Finishing:** Seam shoulders with three-needle bind-off. Pick up stitches around neckline; work collar in stockinette stitch in the round. Bind off in pattern. Fold collar in half; seam cast-off edge of collar to pick-up round with blind stitch. Seam sides and sleeve undersides with mattress stitch. Seam sleeves to body with slip stitch.

## Abbreviations:

BO = bind off

OH = on hold (i.e., place on stitch holder)

PU = pick up

RE = row(s) even

#-#-# = rows-stitches-times

**Back**

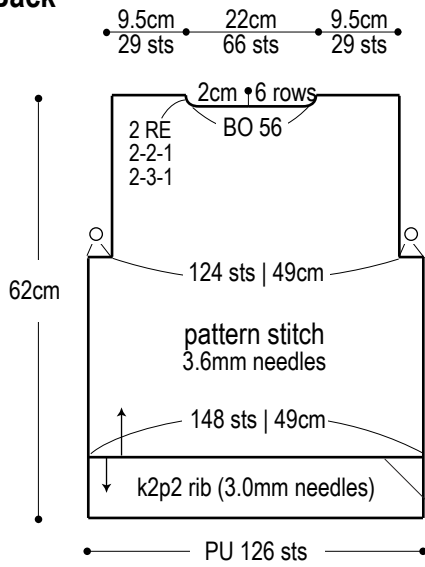

**Front**

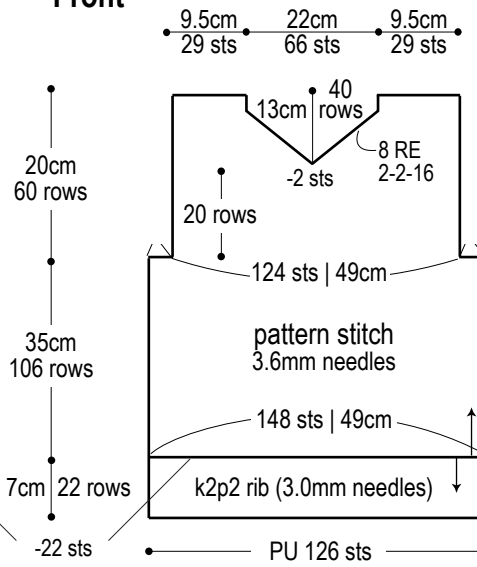

○ = 12 sts OH (4cm)  
 ■ = 12 sts OH (4cm)

**Collar** (stockinette st folded double)  
 2.7mm circular needle

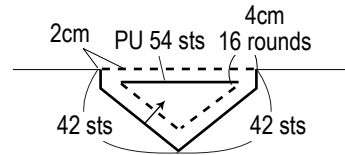

**Sleeve**

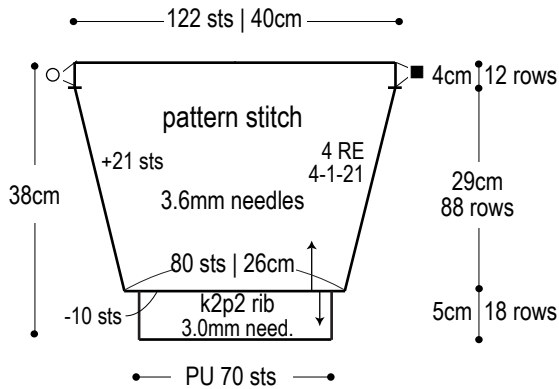

□ = □ knit

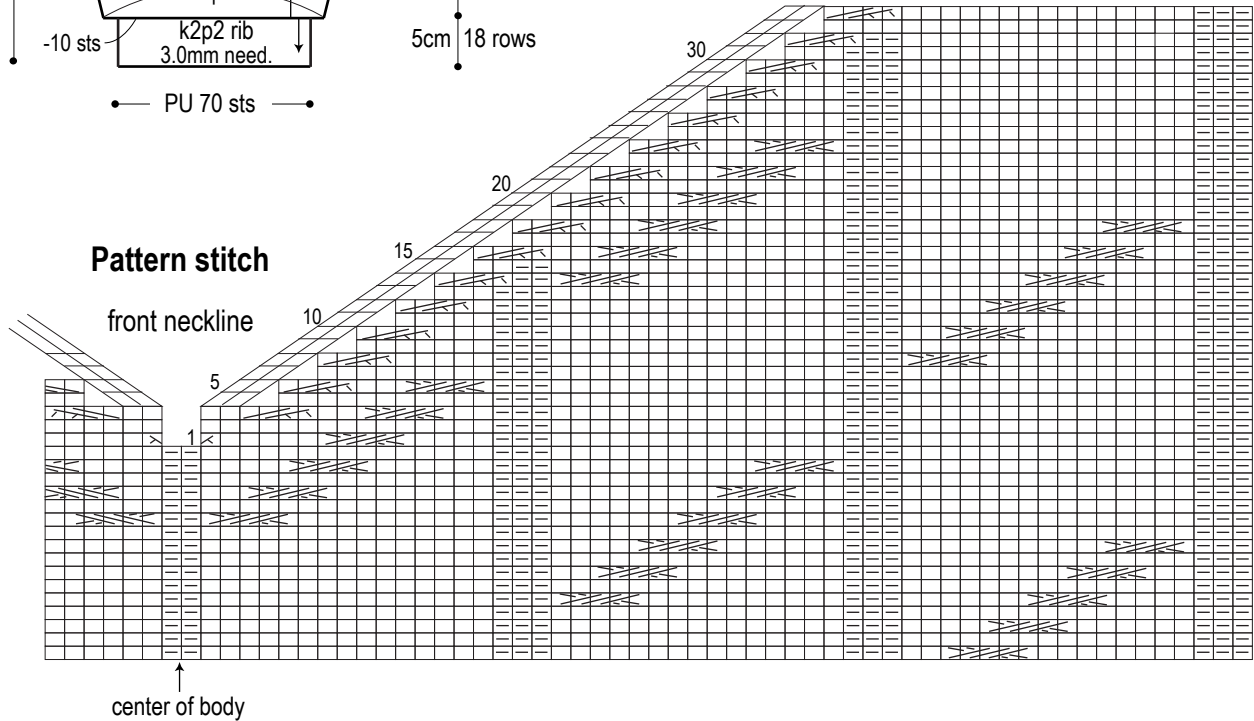

# Pattern stitch

