

27-G604V Sweater with lace edging

© Pierrot Yarns (Gosyo Co., Ltd.). Translation by Linda Lanz.



Materials

- Pierrot Yarns Super Wool [50% wool, 50% cotton; 547 yds / 500m per 3.53 oz. / 100g cone]; color #3 grayish pink; 4 cones [340g]
- 3.6mm (US 4 or 5) knitting needles or size necessary to achieve gauge

Gauge

Gauge is measured in a swatch 10cm/4" square.

- stockinette stitch: 20 sts and 26 rows
- pattern stitch: 22 sts and 28 rows

Finished measurements

- bust 90cm/35.4"
- cross back width 34cm/13.4"
- length 53cm/20.9"
- sleeve length 38cm/15.0"

Knitting Tips

◆**Note:** entire garment is worked with two strands of yarn held together.

Body and armholes: Cast on with long-tail cast-on and knit in pattern stitch. In first row of stockinette, decrease evenly across. For front piece, knit 40 rows of stockinette, then place the center 11 stitches on hold. Continue working right and left sides of front separately. Knit sleeves in same pattern as body. Armholes, neckline, sleeve caps: bind off required number of stitches, then work decreases as required. Work twisted increases (i.e., make 1) along sleeve edges.

Finishing: Join shoulders with three-needle bind-off. Pick up required number of stitches around neckline and work collar in pattern stitch. When finished, bind off from wrong side in pattern. Join sides and sleeve undersides with mattress stitch. Join sleeves to body with slip stitch.

Abbreviations: CO = cast on; BO = bind off; OH = on hold; RE = row(s) even.

●back

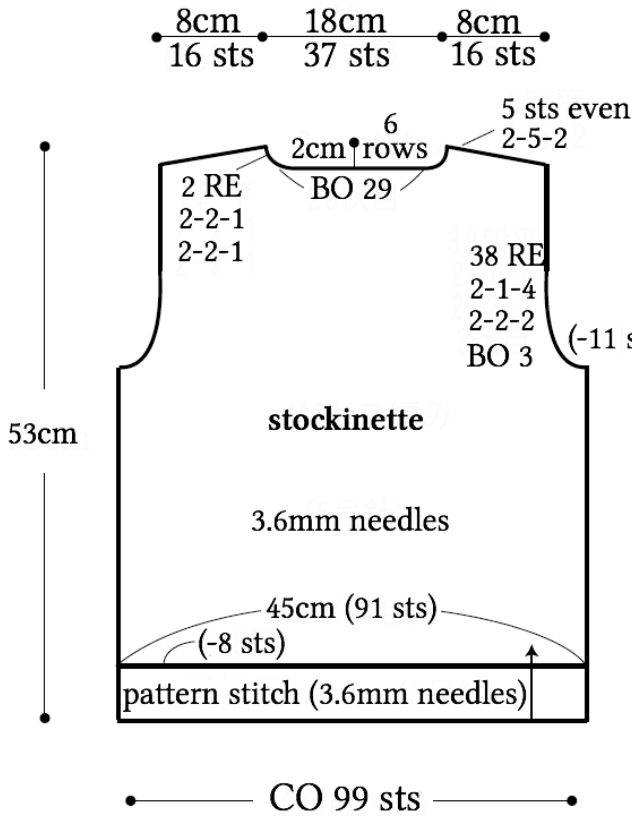

●front

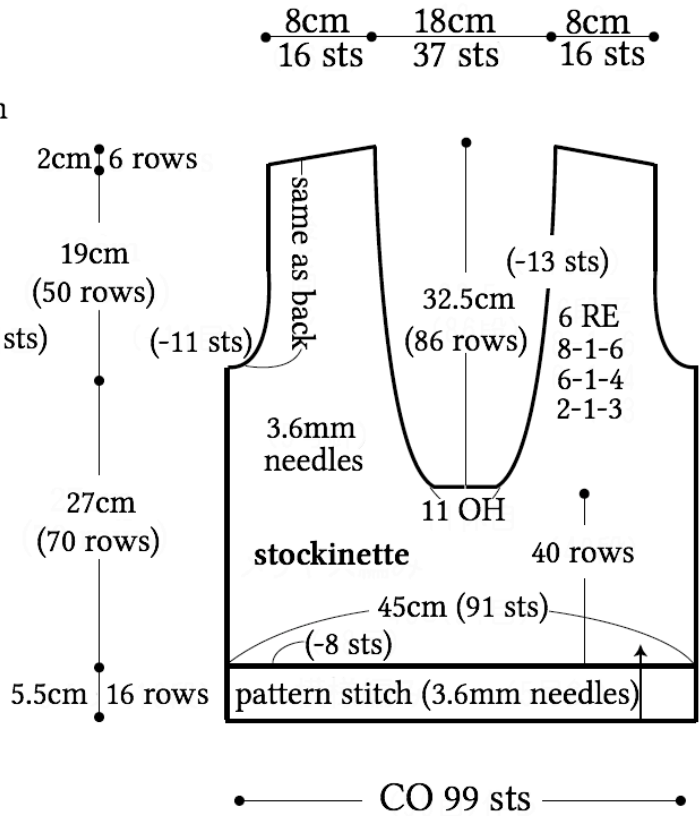

●sleeve

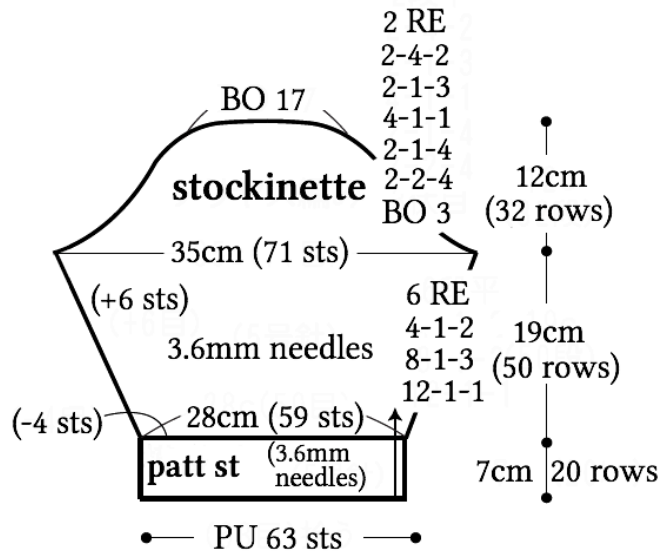

● pattern stitch

□ = □ knit stitch

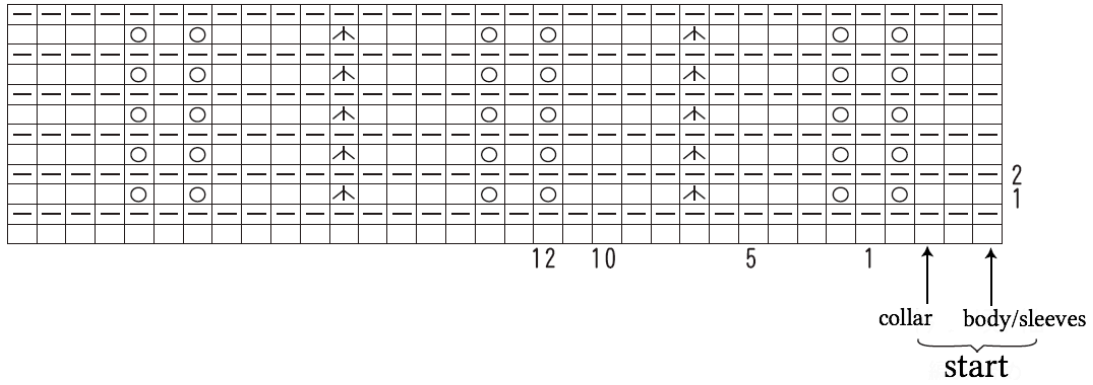

● collar (pattern stitch)

(3.6mm needles)

