

25-26-14 Gradation Sweater

© Pierrot Yarns (Gosyo Co., Ltd.). Translation by Linda Lanz.



Materials

Both suggested yarns have been discontinued. Please substitute with appropriate yarns by matching gauge.

- Pierrot Yarns Gradation [75% kid mohair, 25% nylon; 219yds/200m per 0.88 oz / 25g skein]; color #3; 4 skeins [85g]
- Pierrot Yarns Hotaru2 [67% acrylic, 27% nylon, 6% polyester; 875yds/800m per 3.53 oz / 100g cone]; color #2 red/blue/green/purple/pink gradation lamé; 1 cone [80g]
- 3.0mm and 3.6mm straight knitting needles (US 2½ and 4 are the closest equivalents) or size necessary to achieve gauge
- 3.0mm circular knitting needles (US 2½) or size necessary to achieve gauge
- 2.3mm crochet hook or size necessary to achieve gauge; US B is the closest equivalent

Gauge

- in 10cm/4" square with larger needles: 19 st and 22 rows in pattern stitch

Finished measurements

- bust 94cm/37" back width 35cm/13.8"
- back length 57cm/22.4" sleeve length 45cm/17.7"

Knitting Tips

Body: Using long-tail cast on, knit welt and continue in pattern stitch according to chart. Work armhole and neckline shaping according to chart. Place the center neckline stitch of front piece onto a stitch holder, dividing front into left and right sides. Use same cast on for sleeves as for body, work ribbing and then work frill. On row 1 of sleeve body (that is, first row after the cuff is finished), decrease 82 sts evenly across using k2tog. Work twisted increases one stitch in from edge on sleeve underside.

Finishing: Join shoulders with three-needle bind-off. Join sides and sleeve seams using mattress stitch. Pick up stitches around neckline for collar and work according to chart. See special chart for V-neck shaping. Join sleeves to body using crochet hook and slip stitch.

※ Work garment with 2 strands of yarn held together (1 strand each of Gradation and Hotaru2).

● back

● front

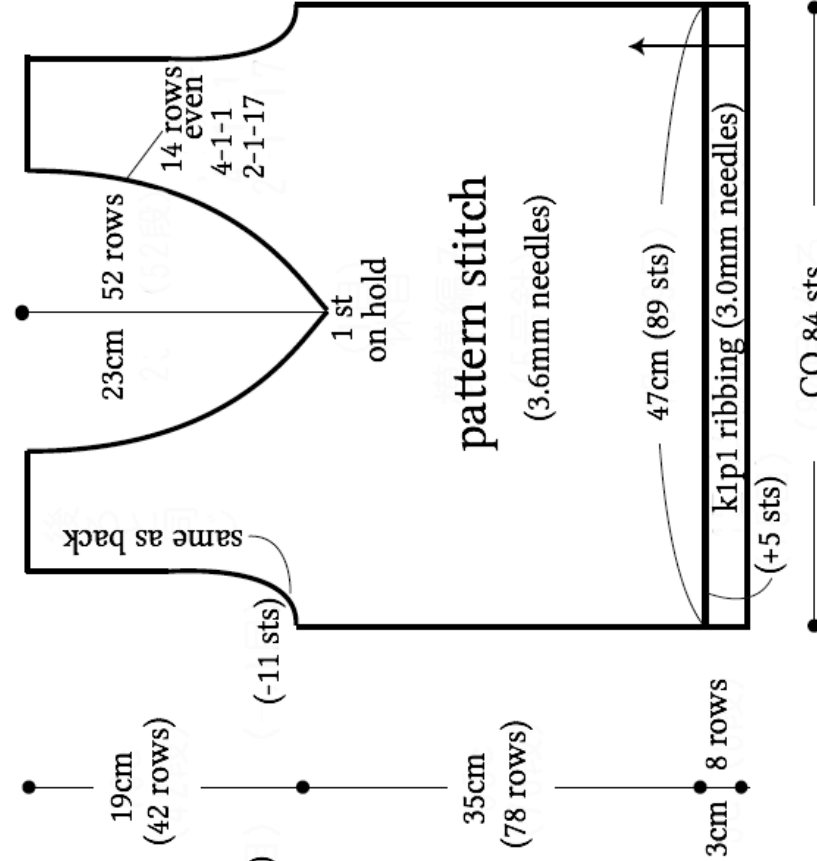
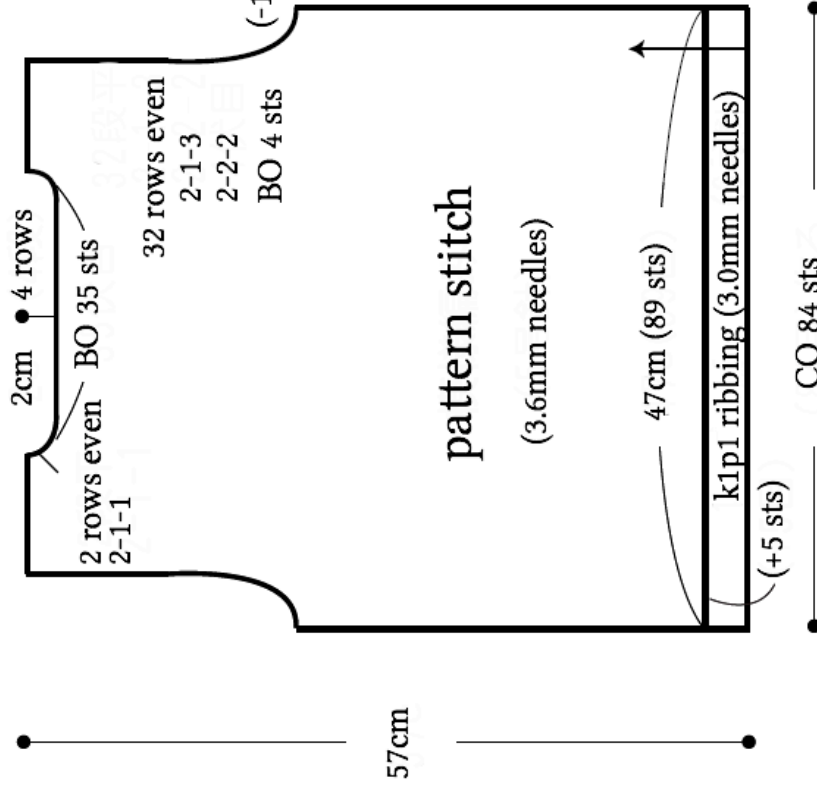
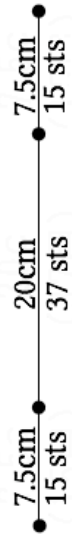
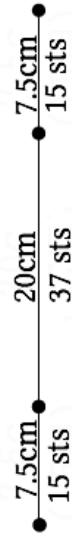

2.11.2024 9:51:02

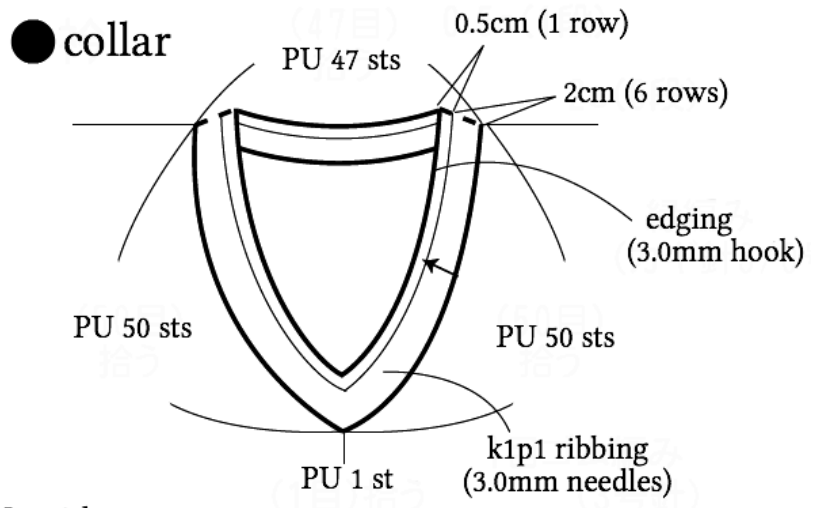
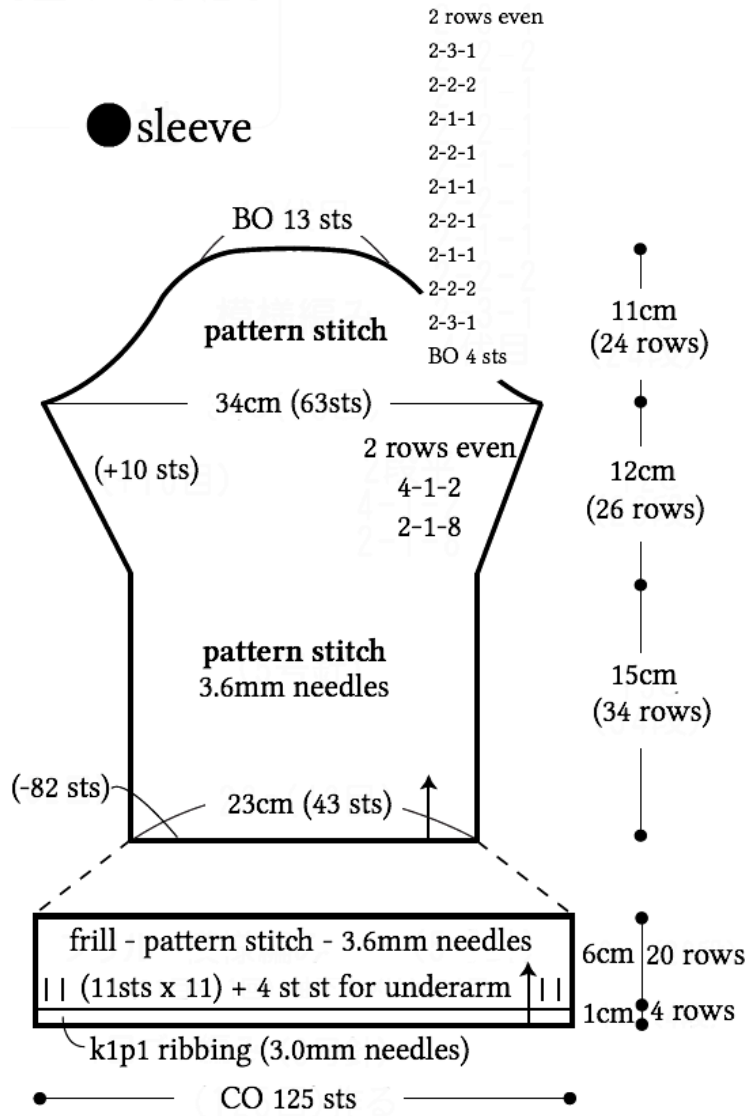

PU = pick up

● pattern stitch chart

