

575pouch Belt Pouch



Suggested yarn:

- Pierrot Yarns Ami Cotton Bulky [100% cotton; 115 yds/105m per 3.53 oz./100g hank]; color #05 baby blue, 2 hanks [190g]

Tools/Notions:

- 3.5mm (US E) crochet hook or size necessary to achieve gauge
- 2 rectangle buckle rings (like D-rings but rectangular), 25mm/1"
- 1 magnetic purse clasp (14mm/0.6")
- 3 snaps (12mm/0.5")
- 3 decorative buttons (23mm/0.9")
- 1 fabric label, badge, or appliqué (the one shown says "beach")

Finished measurements:

- width 17cm/6.7"
- depth 19cm/7.5"
- gusset width 9cm/3.5"

Gauge (10cm/4" square):

- half double crochet (US): 14 sts and 10 rows
- single crochet (US): 14 sts and 16 rows

Gauge may vary according to individual crochet style. Change hook size if necessary to achieve gauge. Alternatively, rework pattern with your own gauge measurements.

Summary

✳️**Note:** Like all Japanese patterns, stitch counts given here for foundation chains do not include any chain sts needed for turning posts.

Body & gusset: Work foundation chain to begin, then work in hdc.

Belt loops: Make 2 each of parts A & B in sc.

Gusset finishing: Crochet two chains, each 5 chain sts long, and reserve for use later.

Finishing: With wrong sides facing each other, seam body and gusset pieces together from body side using sc to work through both layers. Fold each part A belt loop in half and thread a rectangle buckle ring through it; seam to back of pouch (one on the left side, one on the right side). Referring to finishing schematics, fasten all magnetic clasps, snaps, and buttons to pouch as indicated. At the mouth of the bag, fasten a gusset chain (made in advance) to each end of the gusset to prevent the gusset from stretching out. Fasten a fabric label, badge, or appliqué of your choice to the lower front of the pouch.

Abbreviations:

ch = chain
hdc = half double crochet (US)
RS = right side
sc = single crochet (US)
WS = wrong side

Body of pouch 3.5mm hook

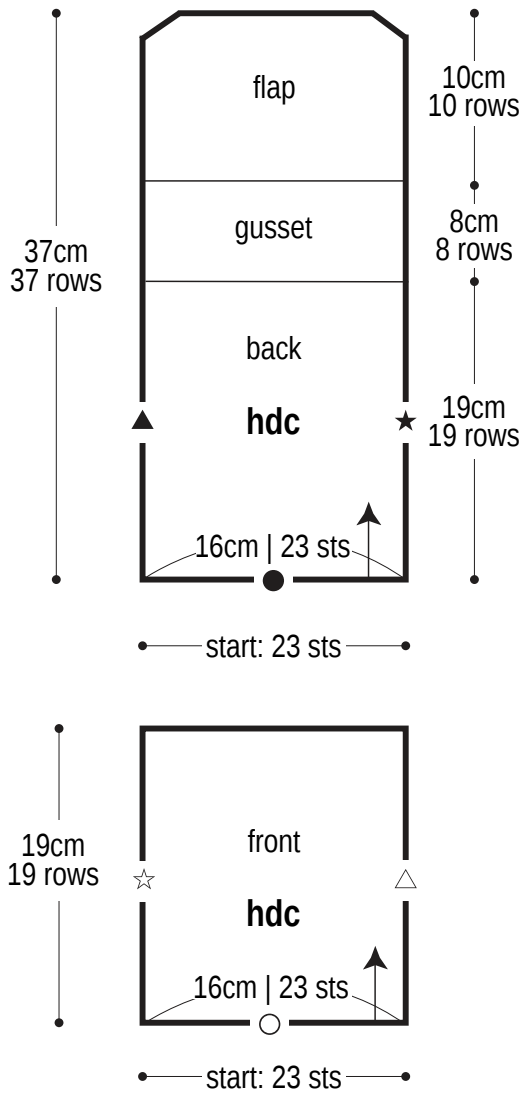

Gusset 3.5mm hook

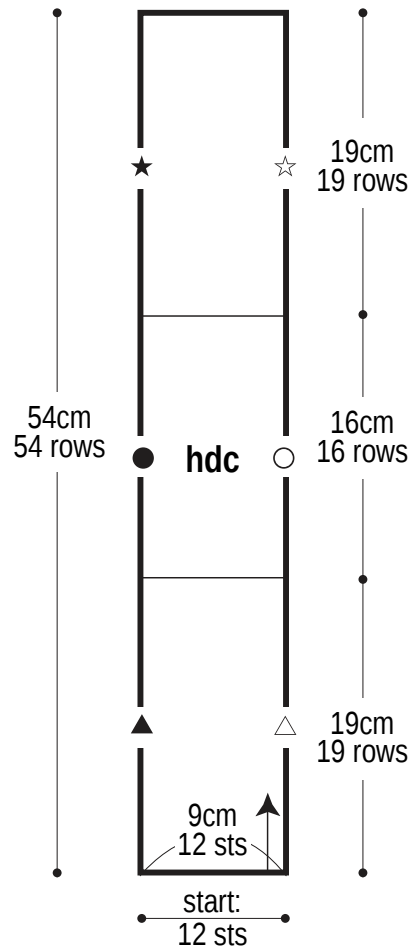
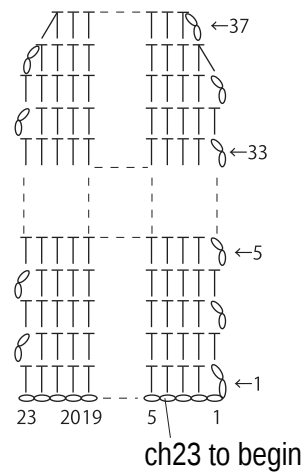

Chart 1



Belt loops (make 2 of each)

3.5mm hook

part A

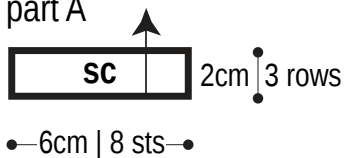

part B

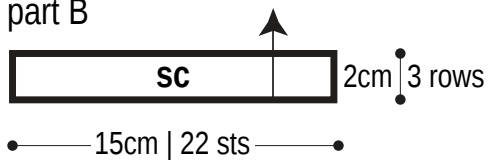

Gusset finishing (make 2)

3.5mm hook

Leave approx. 10cm tail at each end.

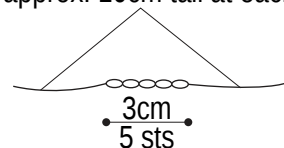

Finishing

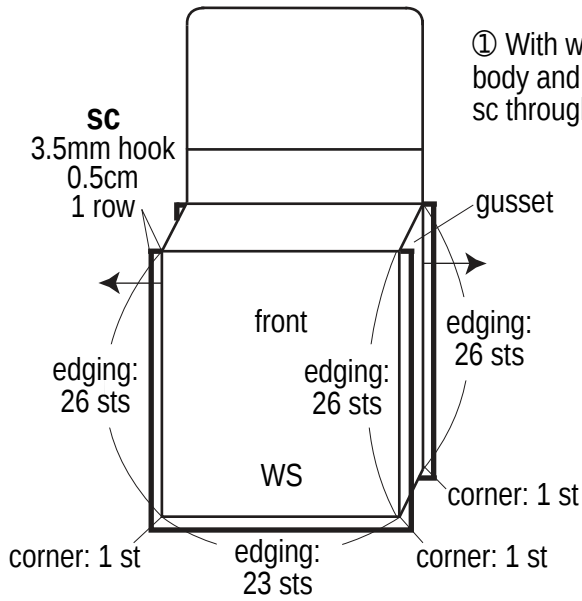

① With wrong sides facing each other, seam body and gusset pieces together by working sc through both layers from body side.

② Fold part A in two and insert rectangle buckle ring into the fold. Seam to right side of back as shown.

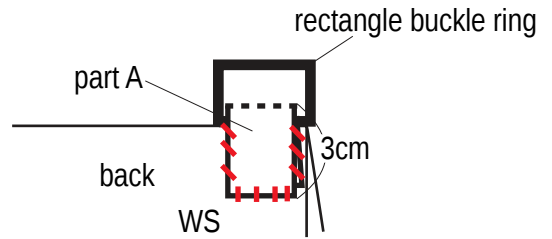

③ Thread part B through D-ring as shown. Sew buttons where indicated.

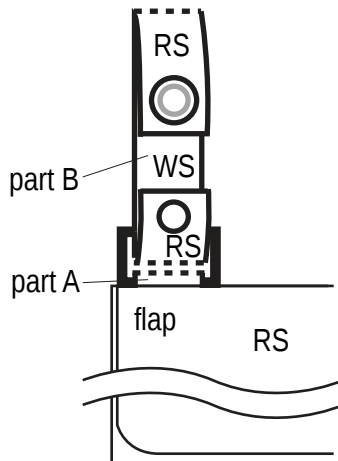

Fasten snap to wrong side.

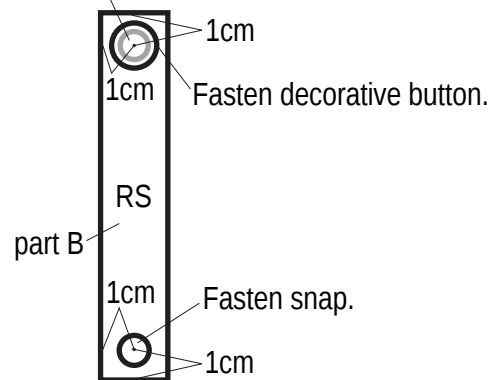

④ Fasten magnetic clasp parts to wrong side of flap and right side of front.

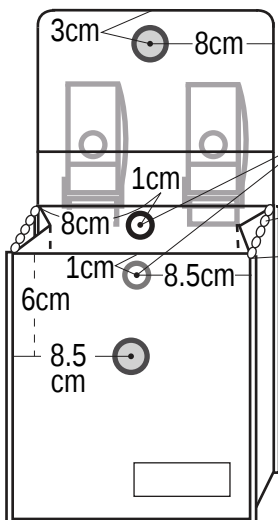

⑤ Fasten snap parts to wrong side of back & front, respectively.

Fasten gusset chain here to finish gusset.

⑥ Secure each yarn tail to the sides of gusset.

⑦ Fasten decorative button to right side of flap.

