

426tie Melange Tie



Suggested yarn:

- Pierrot Yarns Melange Silpalon [50% silk, 50% silpalon acrylic; 492 yds/450m per 3.53 oz./100g cone]; color #12 cobalt spinel, 1 cone [70g]

Tools/Notions:

- 2.5mm (approx. US B or C) crochet hook or size necessary to achieve gauge

Finished measurements:

- width 6.5cm/2.56"
- length 140.5cm/55.31"

Gauge (10cm/4" square):

- pattern stitch: 30 sts and 26 rows

Gauge may vary according to individual crochet style. Change hook size if necessary to achieve gauge. Alternatively, rework pattern with your own gauge measurements.

Summary

❖**Note:** Work entire necktie with 2 strands of yarn held together.

Work foundation chain to begin, then work necktie in pattern stitch for 104 rows. Referring to chart, begin shaping for 59 rows, increasing and decreasing as indicated. Then continue for 200 more rows without shaping. After last row, continue by working edging in the round around entire outer edge of necktie.

Abbreviations:

ch = chain
sc = single crochet (US)

Necktie schematic

2.5mm hook

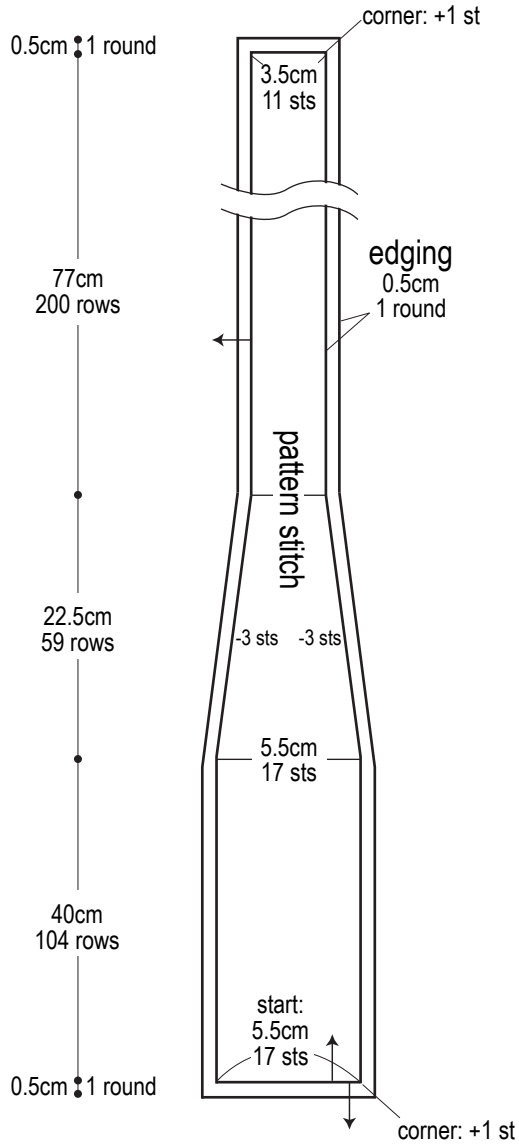

※Refer to chart for edging pattern.

Necktie chart

2.5mm hook

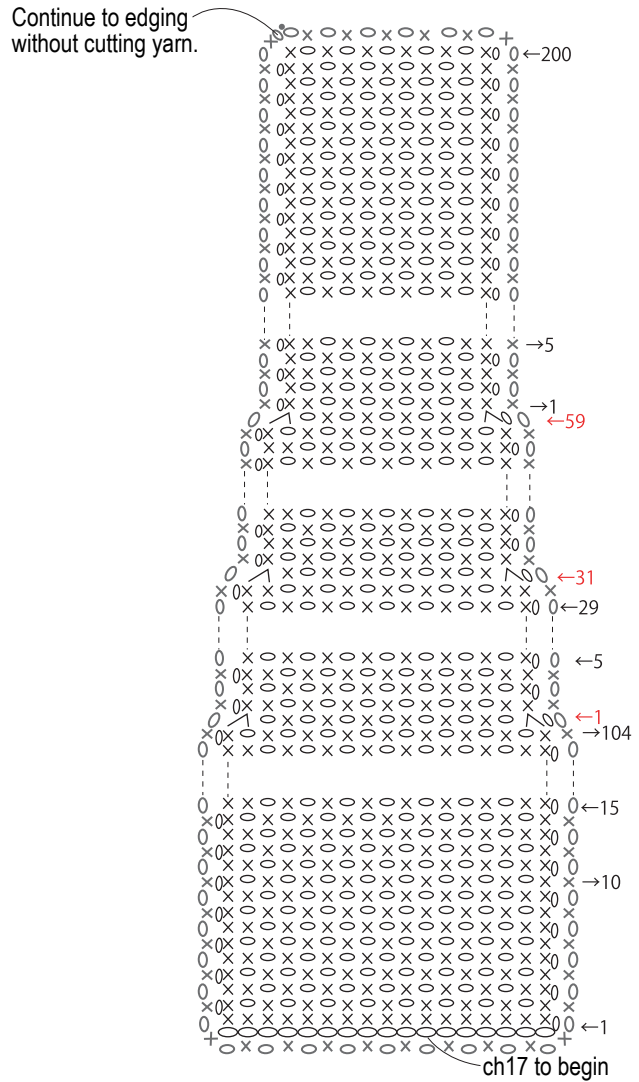

※Note: red numbers refer to decrease rows (decrease on both edges).