

651cd Silk Rosa Dolman Cardigan



Suggested yarn:

- Pierrot Yarns Silk Rosa [75% super kid mohair, 25% silk; 213 yds/195m per 0.88 oz./25g skein]; color #03 loam brown, 3 skeins [280g]

Tools/Notions:

- 5.7mm (approx. US 9) knitting needles or size necessary to achieve gauge
- 5.0mm (US H) crochet hook or size necessary to achieve gauge

Finished measurements:

- center back neck-to-cuff 65cm/25.59"
- length 64cm/25.20"

Gauge (10cm/4" square):

- stockinette stitch: 17 sts and 20 rows

Gauge may vary according to individual knitting style. Change needle size if necessary to achieve gauge. Alternatively, rework pattern with your own gauge measurements.

Knitting Tips

Back body: Cast on with long-tail cast-on method. Work in k1p1 ribbing, then continue in stockinette stitch. Seam the two back pieces at back center with mattress stitch.

Front body: Begin as for back. Work in k1p1 ribbing, then continue in k1p1 ribbing, seed stitch, and stockinette stitch. For back collar, continue in k1p1 ribbing. Bind off in pattern stitch.

Finishing: Seam shoulders with crochet slip stitch seam. Seam sleeve undersides with mattress stitch. Seam center of collar with woven seam. Seam back collar and back neckline together with stitches-to-rows mattress stitch.

Abbreviations:

BO = bind off

CO = cast on

k = knit stitch

p = purl stitch

= rows-stitches-times (In this particular pattern, these numbers refer to short row shaping. 2-7-1, for example, means "every 2 rows, work until 7 stitches remain, then wrap and turn (leaving those 7 stitches unworked); do this 1 time.")

Left back body

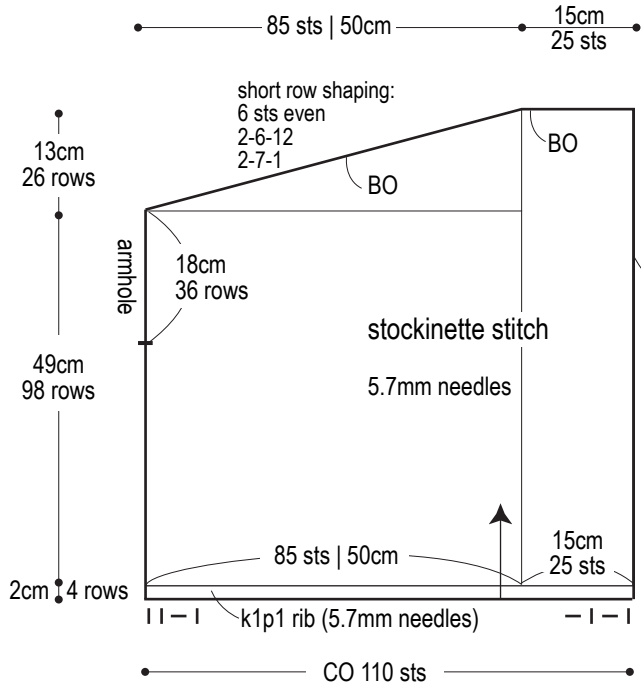

Right back body

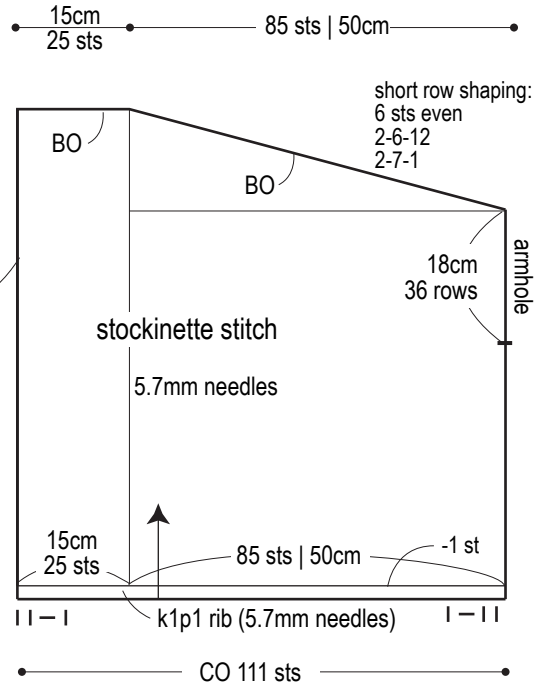

Right front body

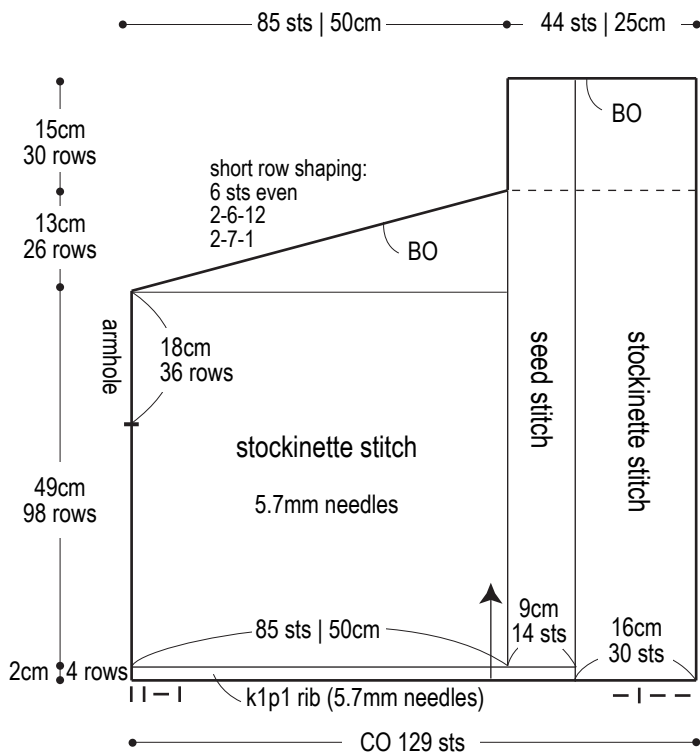

Left front body

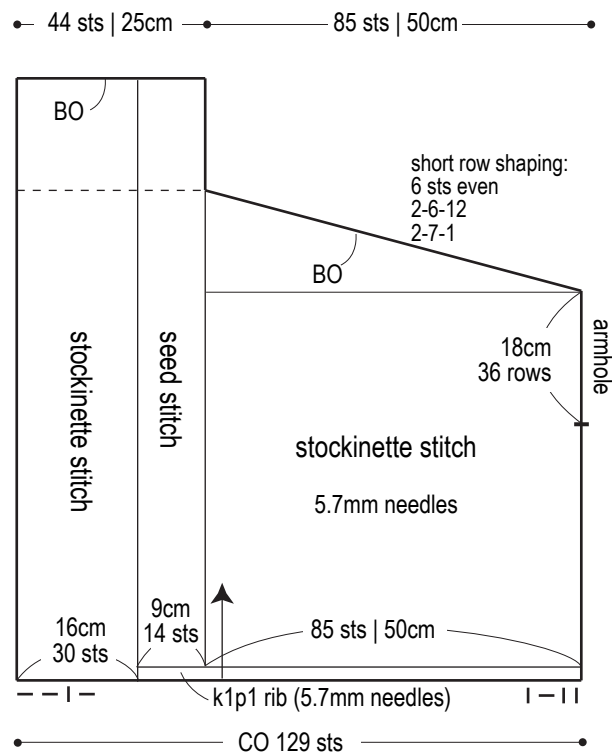

Right front hem

5.7mm needles

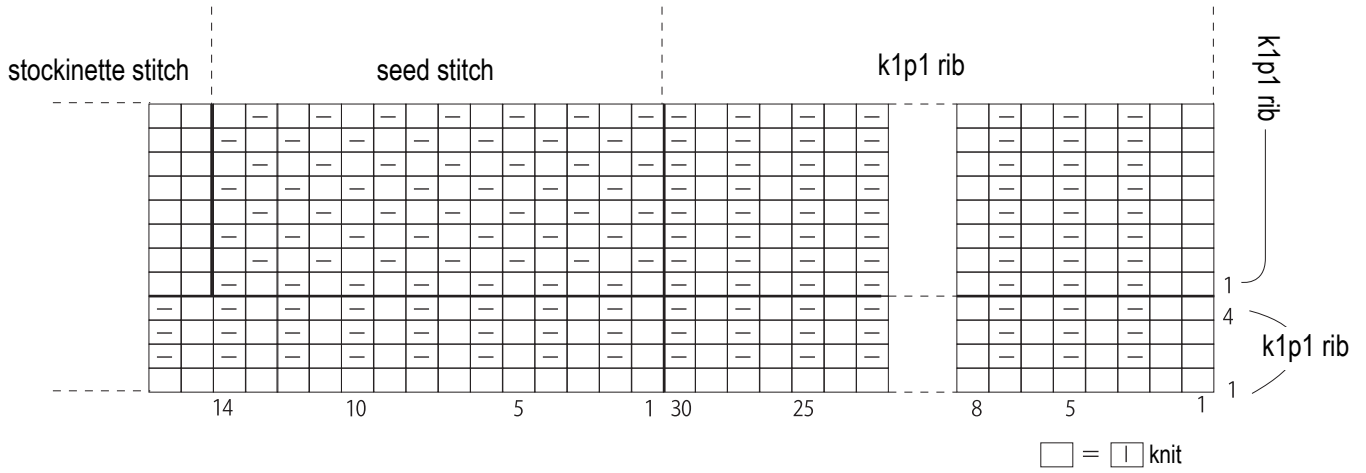

Finishing

