

# 212fw-21 Aspen Triangular Shawl



## Suggested yarn:

- Filatura Botto Poala Aspen 3 [100% cashmere; 107 yds/98m per 0.88 oz./25g skein];
  - color #08 light gray, 3 skeins [70g]
  - color #16 black, 3 skeins [100g]

## Tools/Notions:

- 3.5mm (US E) crochet hook or size necessary to achieve gauge
- 1 corsage pin
- 1 elastic ring (such as a ponytail elastic)

## Finished measurements:

- width 131cm/51.57"
- length 67cm/26.38"

## Gauge (10cm/4" square):

- pattern stitch: 22.5 sts and 11 rows

*Gauge may vary according to individual crochet style. Change hook size if necessary to achieve gauge. Alternatively, rework pattern with your own gauge measurements.*

## Crochet Tips

The shawl is worked sideways in two sections (left and right) from the center outward. To begin, ch140 (17.5 repeats) - note that this does *not* include any chain stitches needed for a turning post. First work left side (chart ①). Then, starting by working into foundation row of left side, work right side (chart ②). Refer to charts for color sequences.

## Abbreviations:

ch = chain

sc = single crochet (US)

———— = #16 black

———— = #08 light gray

----- = change colors without cutting yarn (carry yarn instead)

**Chart ①: left section**  
3.5mm hook

—— = #16 black      —— = #08 light gray  
 - - - - - = when changing colors, carry yarn without cutting

**Crochet tips**

Pay special attention to the chain loops on odd-numbered rows: when working towards short (oblique) edges of triangle (★), fasten these loops down to a row below by working sc around them from underneath.

For example, see the loop marked A in chart ①. When working sc at edge of fifth row (★A), pass ch8 of third row under ch12 of first row and fasten in place by working sc.

For the loop marked B in chart ①, work the sc at the edge of row 9 (★B) as follows: pass the loop in row 3 under the loop in row 1, pass the loop in row 5 under the loop in row 3, and pass the loop in row 7 under the loop in row 5; sc to fasten in place.

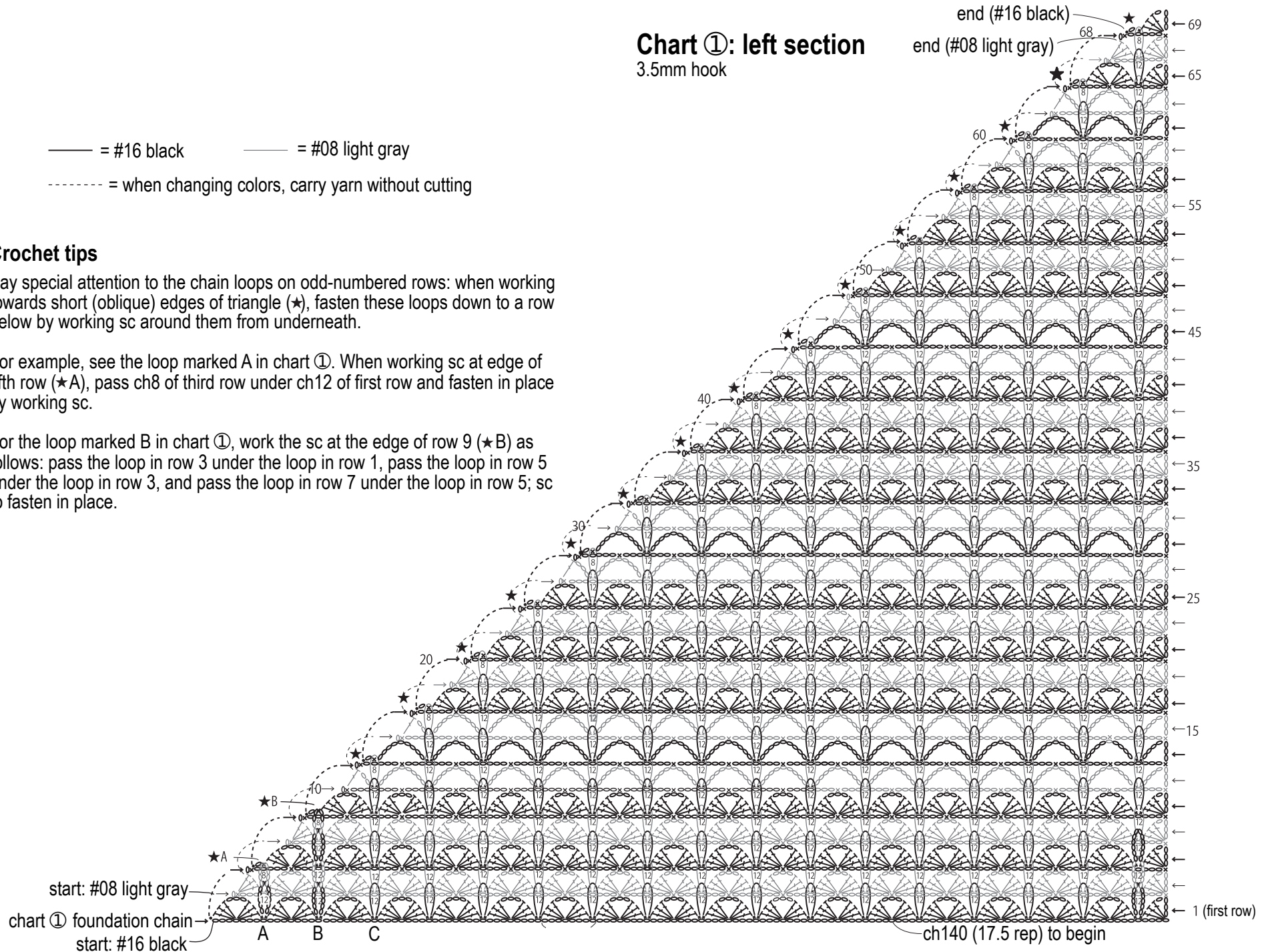

end: #08 light gray

end: #16 black

### Chart ②: right section

3.5mm hook

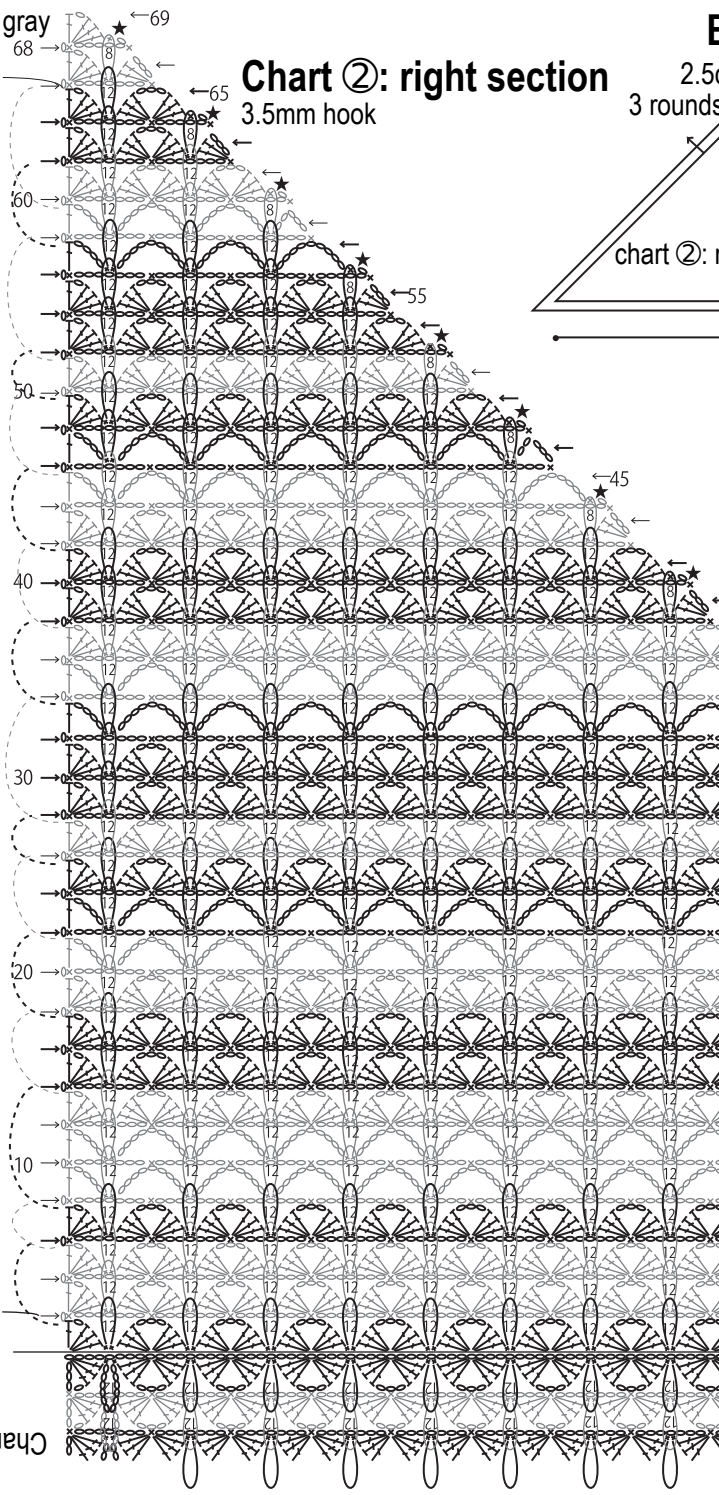

### Edging (3.5mm hook)

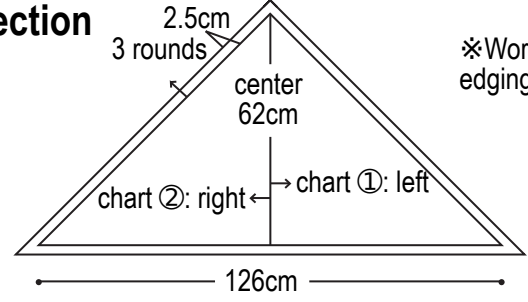

※Work 3 rounds of edging with #16 black.

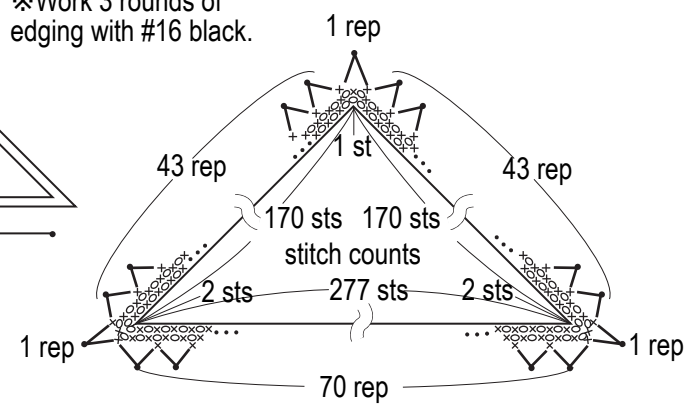

### Edging

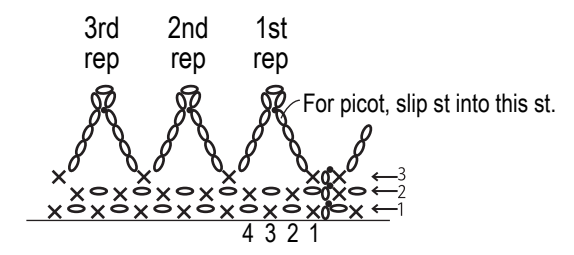

— = #16 black  
— = #08 light gray

start: #08 light gray

Chart ①: left section

Join #16 black and start chart ②.

# Corsage instructions

① Crochet the base.

center: ch5  
 round 1: 8 sc  
 round 2: \*sc, ch2\* 8 times  
 round 3: \*sc, ch3\* 8 times

base:  
 #08 light gray

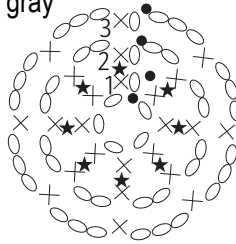

② With #16 black, \*sc, ch10\* into space between rounds 1 and 2 of base (marked with ★).

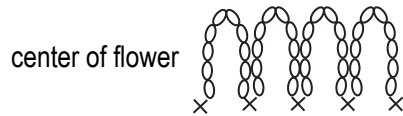

③ Join #08 light gray to ch2 of second round of base (as shown below):

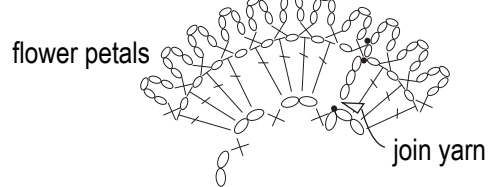

④ Join #08 light gray to ch3 of third round of base (as shown below); crochet 8 petals.

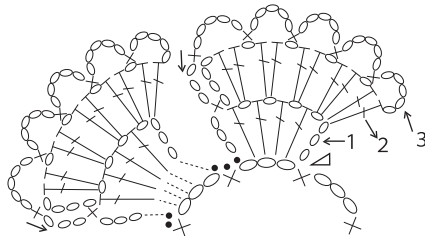

⑤ With #16 black, crochet trim around the 8 petals made in step ④.

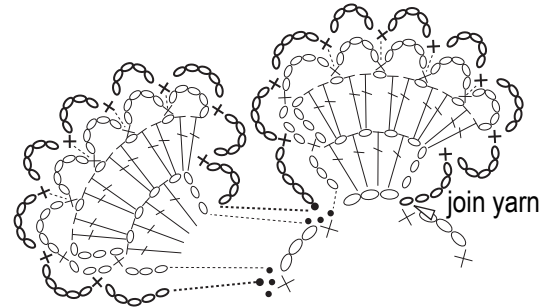

⑥ With #16 black, crochet back piece for the base.

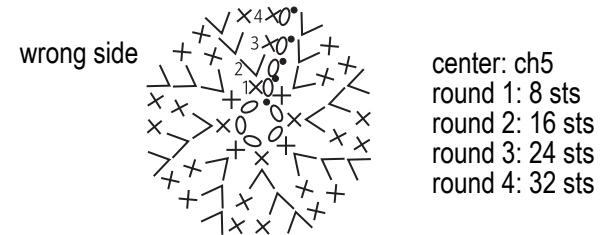

⑦ Sew back piece and base together. Sew corsage pin to back piece.

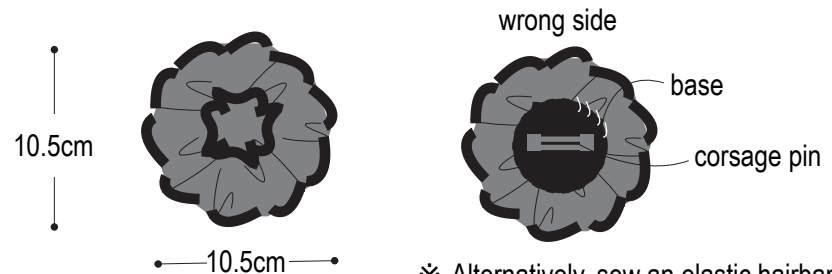

※ Alternatively, sew an elastic hairband to the back to make a hair accessory.