

# amicomo6-13 Colorful Mat



## Suggested yarn:

- Pierrot Yarns Ami Cotton (Super Bulky) [100% cotton; 55 yds/50m per 3.17-3.53 oz./90-100g hank]; color #53 vanilla, 2 hanks [180g]
- scraps of the following 5 yarns in 7 different colors:
  - Pierrot Yarns Ami Cotton (Bulky) [100% cotton; 115 yds/105m per 3.17-3.53 oz./90-100g hank]
  - Pierrot Yarns Ami Cotton Space Dye (Bulky) [100% cotton; 115 yds/105m per 3.17-3.53 oz./90-100g hank]
  - Pierrot Yarns Cotton Neat [100% cotton; 58 yds/53m per 1.41 oz./40g skein]
  - Pierrot Yarns Ethnic Jute [100% jute; 295 yds/270m per 3.17-3.53 oz./90-100g hank]
  - Pierrot Yarns Sawayaka Cotton [100% cotton; 416 yds/380m per 3.53 oz./100g cone]

## Tools/Notions:

- 5.0mm (US H) crochet hook or size necessary to achieve gauge

## Finished measurements:

- 54cm/21.26" by 87cm/34.25"

## Gauge:

- each motif should measure 16cm/6.30" square

*Gauge may vary according to individual crochet style. Change hook size if necessary to achieve gauge. Alternatively, rework pattern with your own gauge measurements.*

## Crochet Tips

**Motifs:** In order to use up yarn remnants, this pattern uses 1 to 4 strands at a time to adjust for yarn thickness. Chain to create foundation row (working into bottom loops). Work in pattern stitch to form squares. Work 1 round of edging. Make 15 motifs total.

※Arrange motifs in order by color, yarn qualities, or however you like.

**Finishing:** With right sides facing upward, seam motifs together in order from step 1 to step 6 (as shown on schematic on page 2) using a combination of chain and single crochet (US) stitches. Crochet edging.

## Abbreviations:

ch = chain

sc = single crochet (US)

**Motif** (make 15 with 5.0mm hook)

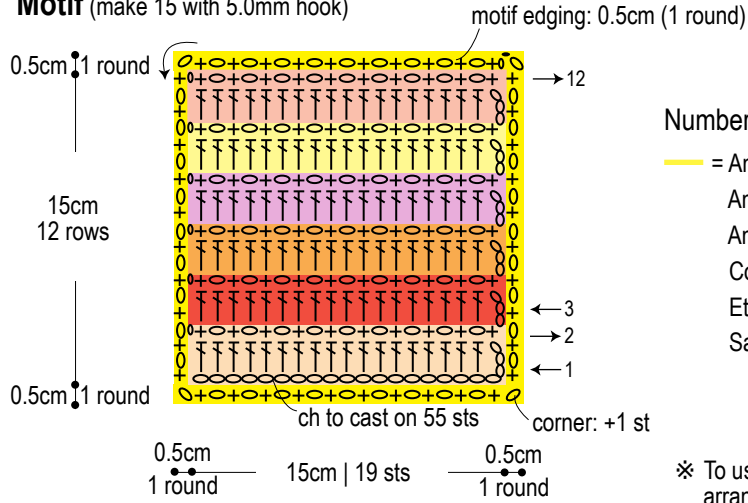

**Number of strands to use for each yarn**

- = Ami Cotton (Super Bulky), color #53 vanilla: use 1 strand
- = Ami Cotton (Bulky): use 1 strand
- = Ami Cotton Space Dye (Bulky): use 1 strand
- = Cotton Neat: use 2 strands
- = Ethnic Jute: use 4 strands
- = Sawayaka Cotton: use 4 strands

※ To use up remnants, use whatever color sequence and arrangement you like.

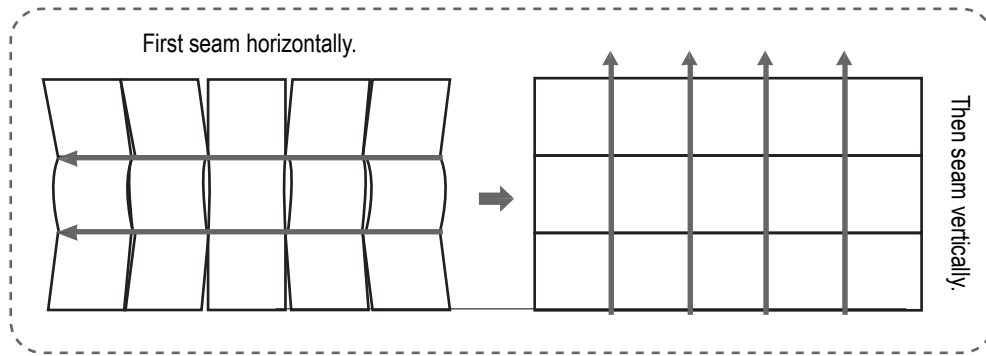

**Mat layout**

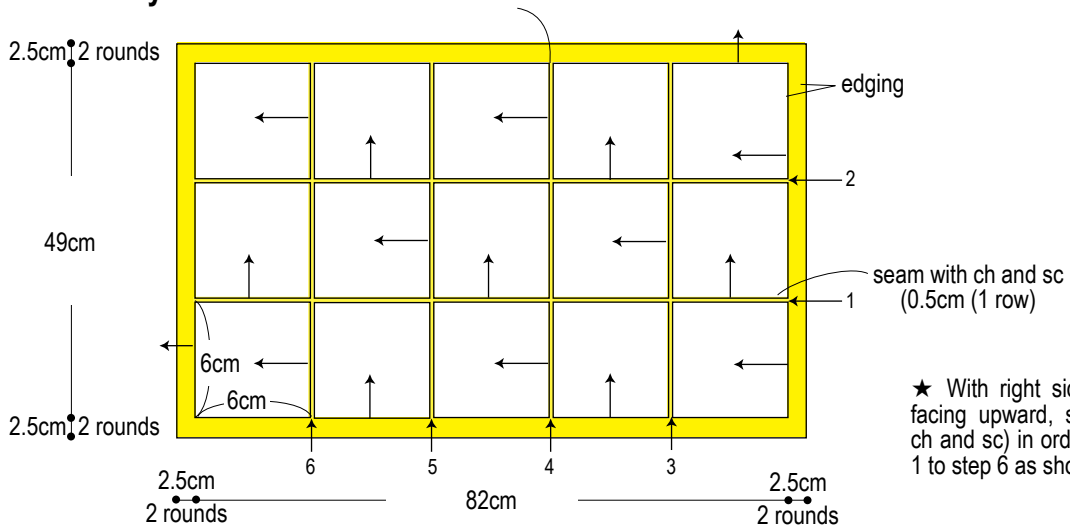

★ With right side of motifs facing upward, seam (using ch and sc) in order from step 1 to step 6 as shown.

# Mat instructions (5.0mm hook)

start edging

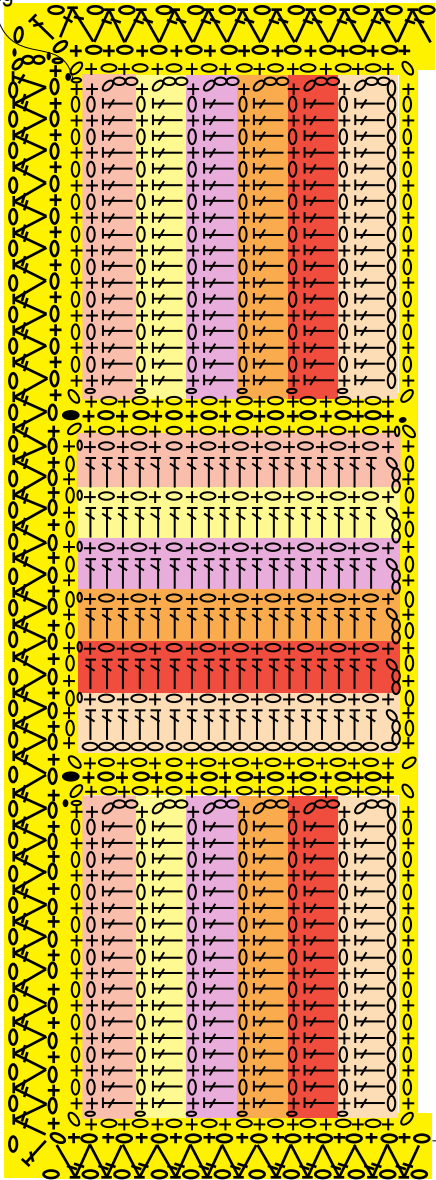

← 2 edging  
 ← 1 2.5cm (2 rounds)

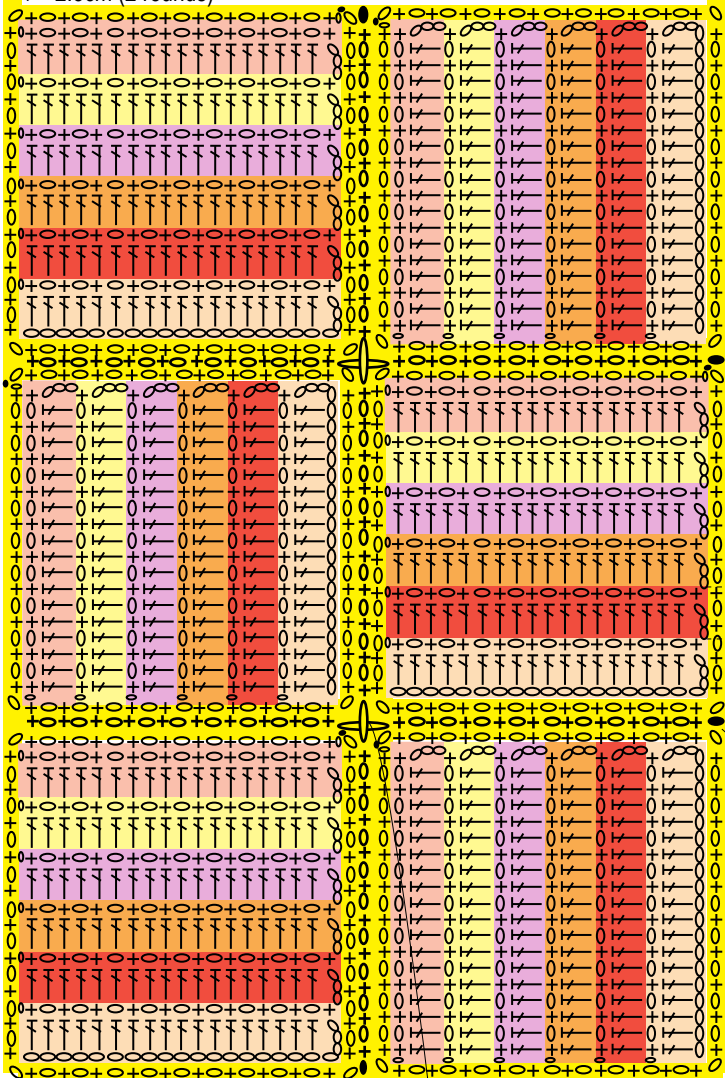

← 2

2 rows = 1 repeat

← 1

start joining motifs here

↑ 3

When doing vertical seams, chain from vertical seam should cross over chain from horizontal seam.